

# **TECHNICAL MANUAL**

## **101.6mm COMMERCIAL FRAME CENTRE GLAZED - DOUBLE GLAZED**

# 101.6mm COMMERCIAL FRAME CENTRE GLAZED - DOUBLE GLAZED

---

## CONTENTS

### 1 SPECIFICATION

1.1 Performance and features

### 2 LOAD CHARTS

2.1-2.7 Wind Pressure Tables

### 3 EXTRUSIONS

3.1 - 3.8 Extrusion profiles

### 4 COMPONENTS

4.1 - 4.3 Accessories

### 5 GENERAL ARRANGEMENTS

5.1 - 5.10 Elevations and plan views

### 6 MACHINING DETAILS

6.1 - 6.4 Punching details

### 7 GLAZING DETAILS

7.1 Double glazed table

### 8 GLAZING DETAILS

8.1 Sub sill sealing details

# 101.6mm COMMERCIAL FRAME CENTRE GLAZED - DOUBLE GLAZED

## SPECIFICATION

---

### FRAME DIMENSIONS

- 101.6mm x 50mm

### MAX PERFORMANCE

- Water Penetration: 600Pa Water

### MAXIMUM SIZES

- Max mullion height: 5100
- Max mullion centres: 2200

Refer wind load charts for sizing and max pressures.

### GLAZING

- Double Glazed: 22mm - 30mm

# 101.6mm COMMERCIAL FRAME CENTRE GLAZED - DOUBLE GLAZED

## LOAD TABLE - RC401 \ RC404 50mm COUPLED MULLION

### SECTION PROPERTIES

$I_{xx}: 992 \times 10^3 \text{ mm}^4$

Alloy: 6060 T5

Max Stress 110 Mpa

S = Serviceability limit state I/250

U = Ultimate limit state

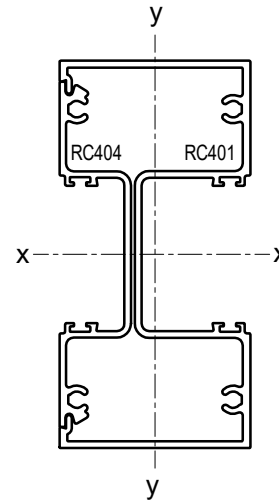

Mullion Height	Maximum Design Pressure (Pa)							
		800	1000	1200	1400	1600	1800	2000
3300	S	750	610					
	U	2010	1620					
3200	S	820	670	570				
	U	2140	1730	1460				
3100	S	910	740	620	550			
	U	2280	1850	1560	1370			
3000	S	1000	820	690	610	550		
	U	2440	1980	1680	1470	1310		
2900	S	1110	910	770	680	610	560	530
	U	2620	2120	1800	1580	1420	1300	1210
2800	S	1240	1010	860	760	690	630	590
	U	2810	2280	1940	1700	1530	1410	1320
2700	S	1390	1130	970	850	770	720	670
	U	3030	2470	2100	1840	1660	1530	1440
2600	S	1560	1270	1090	960	880	810	770
	U	3280	2670	2280	2010	1810	1680	1580
2500	S	1760	1440	1240	1100	1000	930	890
	U	3550	2900	2480	2190	1990	1840	1740
2400	S	2000	1640	1410	1260	1150	1080	1030
	U	3870	3160	2710	2400	2180	2030	1940
<b>Mullion Ctrs</b>		<b>800</b>	<b>1000</b>	<b>1200</b>	<b>1400</b>	<b>1600</b>	<b>1800</b>	<b>2000</b>

This table is based on theoretical section properties

# 101.6mm COMMERCIAL FRAME CENTRE GLAZED - DOUBLE GLAZED

## LOAD TABLE - RC406 / RC407 50mm STD SPLIT MULLION

### SECTION PROPERTIES

$I_{xx}: 1164 \times 10^3 \text{ mm}^4$

Alloy: 6060 T5

Max Stress 110 Mpa

S = Serviceability limit state I/250

U = Ultimate limit state

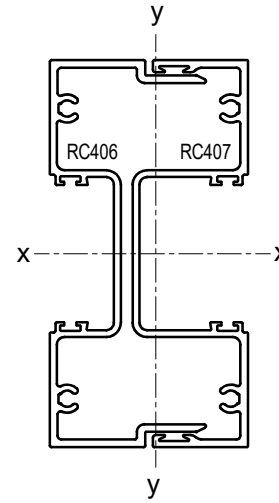

Mullion Height	Maximum Design Pressure (Pa)							
4350	S	880	710	600				
	U	2360	1910	1610				
4200	S	970	780	660	580			
	U	2510	2030	1720	1500			
4050	S	1070	870	730	640	580	530	
	U	2680	2170	1840	1600	1430	1310	
3900	S	1180	960	810	710	640	590	550
	U	2860	2320	1970	1720	1540	1410	1310
3750	S	1310	1060	910	800	720	660	620
	U	3070	2490	2110	1850	1660	1520	1420
3600	S	1460	1190	1010	890	800	740	700
	U	3300	2680	2280	2000	1800	1650	1540
3450	S	1630	1330	1140	1000	910	840	790
	U	3560	2890	2460	2170	1950	1800	1690
3300	S	1830	1500	1280	1130	1030	960	900
	U	3850	3130	2670	2350	2130	1970	1850
3150	S	2070	1690	1450	1290	1170	1090	1040
	U	4170	3400	2910	2570	2330	2160	2050
3000	S	2350	1920	1650	1470	1350	1260	1210
	U	4540	3710	3180	2820	2560	2390	2270
<b>Mullion Ctrs</b>		<b>800</b>	<b>1000</b>	<b>1200</b>	<b>1400</b>	<b>1600</b>	<b>1800</b>	<b>2000</b>

This table is based on theoretical section properties

# 101.6mm COMMERCIAL FRAME CENTRE GLAZED - DOUBLE GLAZED

## LOAD TABLE - RC408 / RC409 50mm HD SPLIT MULLION

### SECTION PROPERTIES

$I_{xx}: 1849 \times 10^3 \text{ mm}^4$

Alloy: 6060 T5

Max Stress 110 Mpa

S = Serviceability limit state I/250

U = Ultimate limit state

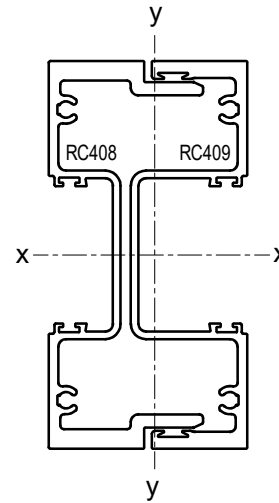

Mullion Height	Maximum Design Pressure (Pa)							
		800	1000	1200	1400	1600	1800	2000
5700	S	1400	1130	960	840	750	680	630
	U	3740	3030	2560	2230	1990	1810	1670
5400	S	1540	1250	1060	930	830	760	700
	U	3990	3230	2730	2380	2130	1940	1790
5100	S	1700	1380	1170	1020	920	840	780
	U	4260	3450	2920	2550	2280	2080	1930
4800	S	1880	1520	1300	1140	1020	940	880
	U	4550	3690	3130	2740	2450	2240	2080
4500	S	2080	1690	1440	1270	1140	1050	980
	U	4880	3960	3360	2940	2640	2420	2260
4200	S	2320	1890	1610	1420	1280	1180	1110
	U	5240	4260	3620	3180	2860	2630	2460
3900	S	2590	2120	1810	1600	1450	1340	1260
	U	5650	4600	3910	3440	3110	2860	2680
3600	S	2910	2380	2040	1800	1640	1520	1440
	U	6000	4980	4250	3740	3380	3130	2950
3300	S	3000	2690	2310	2050	1870	1740	1660
	U	6000	5410	4620	4080	3700	3440	3250
3000	S	3000	3000	2630	2340	2150	2010	1920
	U	6000	5900	5050	4480	4070	3800	3610
<b>Mullion Ctrs</b>		<b>800</b>	<b>1000</b>	<b>1200</b>	<b>1400</b>	<b>1600</b>	<b>1800</b>	<b>2000</b>

This table is based on theoretical section properties

# 101.6mm COMMERCIAL FRAME CENTRE GLAZED - DOUBLE GLAZED

## LOAD TABLE - RC441 \ RC404 COUPLED MULLION - 44mm

### SECTION PROPERTIES

$I_{xx}: 922 \times 10^3 \text{ mm}^4$

Alloy: 6060 T5

Max Stress 110 Mpa

S = Serviceability limit state 1/250

U = Ultimate limit state

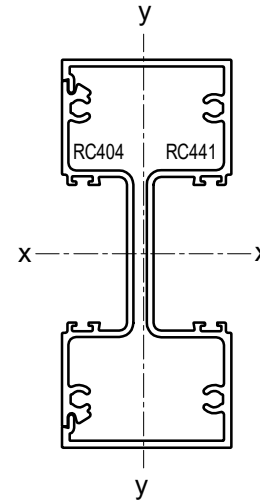

Mullion Height	Maximum Design Pressure (Pa)							
		800	1000	1200	1400	1600	1800	2000
3300	S	700	560					
	U	1860	1510					
3200	S	770	620	530				
	U	1990	1610	1360				
3100	S	840	680	580				
	U	2120	1720	1450				
3000	S	930	760	640	560			
	U	2270	1840	1560	1360			
2900	S	1040	840	720	630	570		
	U	2430	1970	1670	1470	1320		
2800	S	1150	940	800	700	640	590	550
	U	2610	2120	1800	1580	1420	1310	1220
2700	S	1290	1050	900	790	720	660	630
	U	2820	2290	1950	1710	1550	1420	1340
2600	S	1450	1180	1010	900	810	760	720
	U	3040	2480	2110	1860	1690	1560	1470
2500	S	1640	1340	1150	1020	930	870	820
	U	3300	2690	2300	2030	1840	1710	1620
2400	S	1860	1520	1310	1170	1070	1000	960
	U	3590	2940	2520	2230	2030	1890	1800
<b>Mullion Ctrs</b>		<b>800</b>	<b>1000</b>	<b>1200</b>	<b>1400</b>	<b>1600</b>	<b>1800</b>	<b>2000</b>

This table is based on theoretical section properties

# 101.6mm COMMERCIAL FRAME CENTRE GLAZED - DOUBLE GLAZED

## LOAD TABLE - RC405 TRANSOM

### SECTION PROPERTIES

$I_{xx}: 1769 \times 10^3 \text{ mm}^4$

$I_{yy}: 227 \times 10^3 \text{ mm}^4$

Alloy: 6060 T5

Max Stress 110 Mpa

S = Serviceability limit state I/250

U = Ultimate limit state

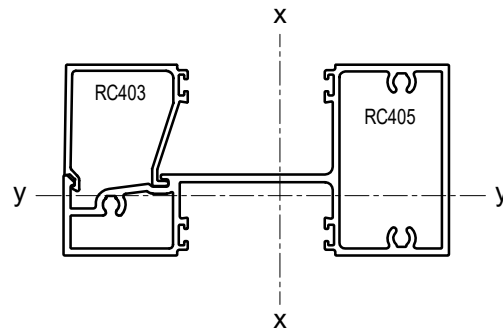

Transom Ctrs	Maximum Design Pressure (Pa)							
	<b>1700</b>	S	3000	3000	3000	2850	2230	
	U	6000	6000	4270	3390	2760		
<b>1600</b>	S	3000	3000	3000	3000	2250		
	U	6000	6000	4500	3550	2790		
<b>1500</b>	S	3000	3000	3000	3000	2300		
	U	6000	6000	4740	3610	2860		
<b>1400</b>	S	3000	3000	3000	3000	2360		
	U	6000	6000	4780	3680	2950		
<b>1300</b>	S	3000	3000	3000	3000	2450		
	U	6000	6000	4870	3800	3070		
<b>1200</b>	S	3000	3000	3000	3000	2570	1960	
	U	6000	6000	5030	3970	3220	2680	
<b>1100</b>	S	3000	3000	3000	3000	2720	2080	
	U	6000	6000	5260	4180	3420	2850	
<b>1000</b>	S	3000	3000	3000	3000	2910	2240	
	U	6000	6000	5570	4470	3670	3080	
<b>900</b>	S	3000	3000	3000	3000	3000	2440	1930
	U	6000	6000	5990	4840	3990	3360	2860
<b>800</b>	S	3000	3000	3000	3000	3000	2690	2130
	U	6000	6000	6000	5320	4410	3720	3180
<b>Max Weight</b>								
<b>Transom length</b>		<b>1200</b>	<b>1350</b>	<b>1500</b>	<b>1650</b>	<b>1800</b>	<b>1950</b>	<b>2100</b>

This table is based on theoretical section properties

# 101.6mm COMMERCIAL FRAME CENTRE GLAZED - DOUBLE GLAZED

## LOAD TABLE - RC402 / RC404 TRANSOM

### SECTION PROPERTIES

$I_{xx}: 787 \times 10^3 \text{ mm}^4$

$I_{yy}: 112 \times 10^3 \text{ mm}^4$

Alloy: 6060 T5

Max Stress 110 Mpa

S = Serviceability limit state I/250

U = Ultimate limit state

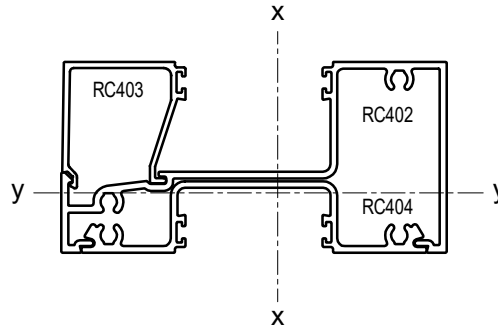

Moments of inertia:

X: 99647.8

Y: 565168.77

Moments of inertia:

X: 13

Y: 222

Transom Ctrs	Maximum Design Pressure (Pa)							
1700	S	3000	3000	3000	3000			
	U	6000	6000	4700	3850			
1600	S	3000	3000	3000	3000			
	U	6000	6000	4970	3940			
1500	S	3000	3000	3000	3000			
	U	6000	6000	5240	3980			
1400	S	3000	3000	3000	3000			
	U	6000	6000	5270	4070			
1300	S	3000	3000	3000	3000	2760		
	U	6000	6000	5380	4200	3390		
1200	S	3000	3000	3000	3000	2890		
	U	6000	6000	5550	4380	3560		
1100	S	3000	3000	3000	3000	3000		
	U	6000	6000	5800	4620	3780		
1000	S	3000	3000	3000	3000	3000		
	U	6000	6000	6000	4930	4050		
900	S	3000	3000	3000	3000	3000		
	U	6000	6000	6000	5340	4410		
800	S	3000	3000	3000	3000	3000		
	U	6000	6000	6000	5870	4870		
<b>Max Weight</b>		120	120	120	90	70		
<b>Transom length</b>		<b>1200</b>	<b>1350</b>	<b>1500</b>	<b>1650</b>	<b>1800</b>	<b>1950</b>	<b>2100</b>

This table is based on theoretical section properties

# 101.6mm COMMERCIAL FRAME CENTRE GLAZED - DOUBLE GLAZED

## LOAD TABLE - RC442 / RC404 TRANSOM

### SECTION PROPERTIES

$I_{xx}: 789 \times 10^3 \text{ mm}^4$

$I_{yy}: 79 \times 10^3 \text{ mm}^4$

Alloy: 6060 T5

Max Stress 110 Mpa

S = Serviceability limit state I/250

U = Ultimate limit state

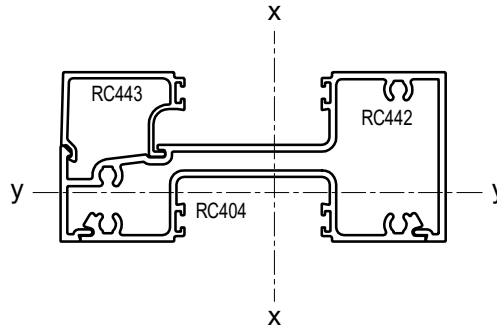

Transom Ctrs	Maximum Design Pressure (Pa)							
1700	S	3000	3000	3000				
	U	6000	6000	5350				
1600	S	3000	3000	3000	3000			
	U	6000	6000	5430	4130			
1500	S	3000	3000	3000	3000			
	U	6000	6000	5490	4170			
1400	S	3000	3000	3000	3000			
	U	6000	6000	5530	4260			
1300	S	3000	3000	3000	3000			
	U	6000	6000	5640	4400			
1200	S	3000	3000	3000	3000	2890		
	U	6000	6000	5820	4590	3730		
1100	S	3000	3000	3000	3000	3000		
	U	6000	6000	6000	4840	3960		
1000	S	3000	3000	3000	3000	3000		
	U	6000	6000	6000	5170	4250		
900	S	3000	3000	3000	3000	3000		
	U	6000	6000	6000	5600	4620		
800	S	3000	3000	3000	3000	3000		
	U	6000	6000	6000	6000	5100		
Max Weight		120	120	100	73	55		
Transom length		1200	1350	1500	1650	1800	1950	2100

This table is based on theoretical section properties

# 101.6mm COMMERCIAL FRAME CENTRE GLAZED - DOUBLE GLAZED EXTRUSION PROFILES

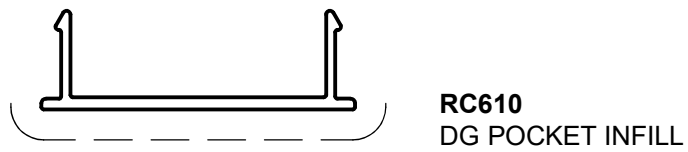
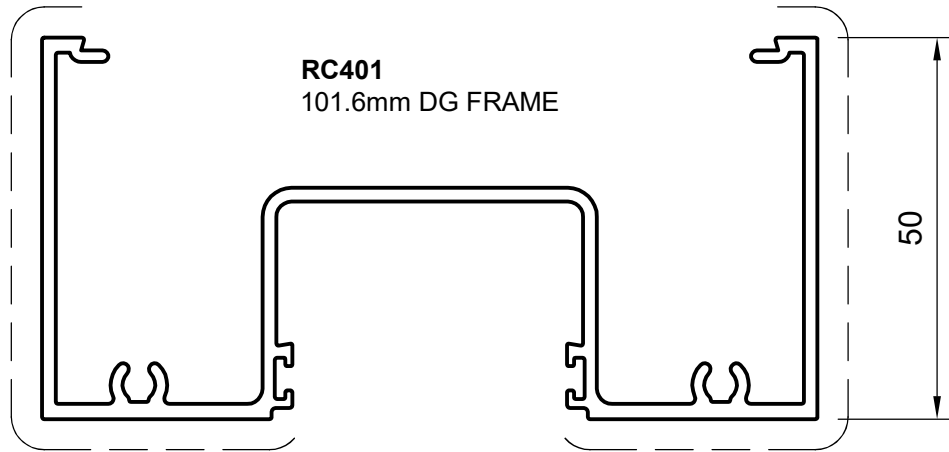

**RC403**  
101.6mm DG BEAD

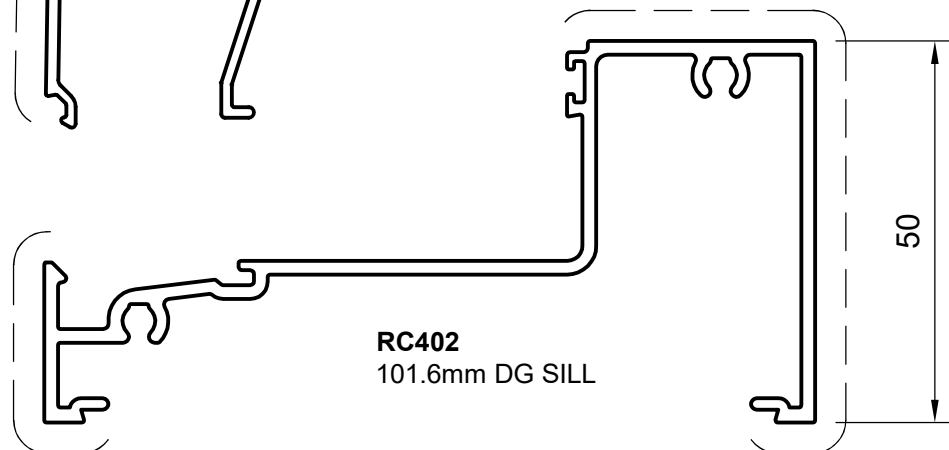
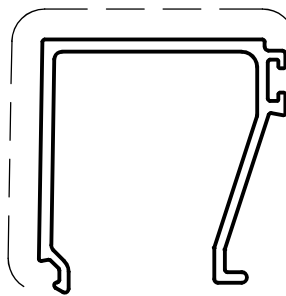

# 101.6mm COMMERCIAL FRAME CENTRE GLAZED - DOUBLE GLAZED EXTRUSION PROFILES

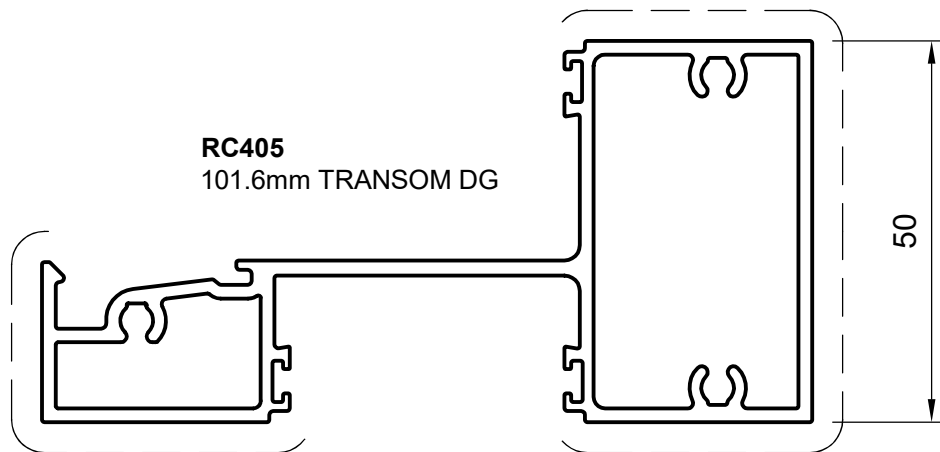

**CF405**  
101.6mm FLAT FILLER

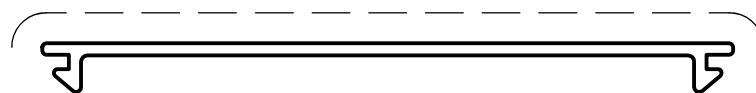

**RC404**  
101.6mm GLAZING ADAPTOR DG



# 101.6mm COMMERCIAL FRAME CENTRE GLAZED - DOUBLE GLAZED

## EXTRUSION PROFILES

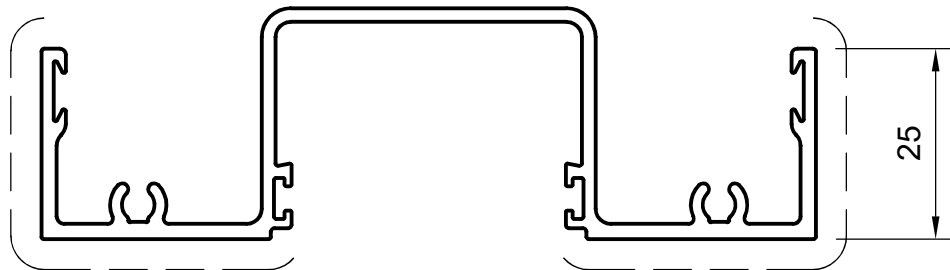
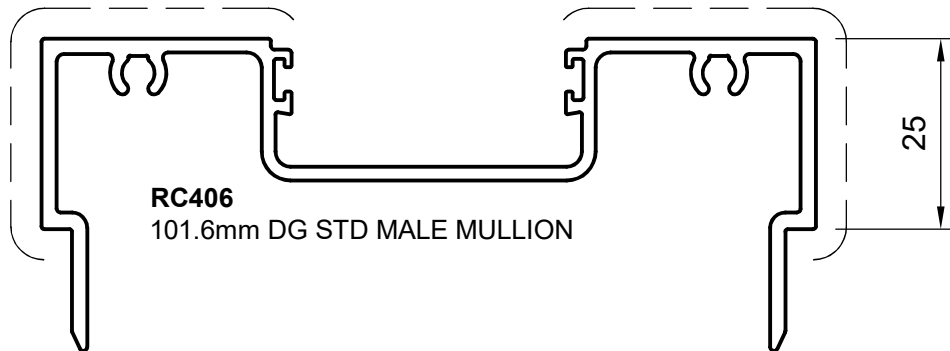

**RC408**  
101.6mm DG HD MALE MULLION

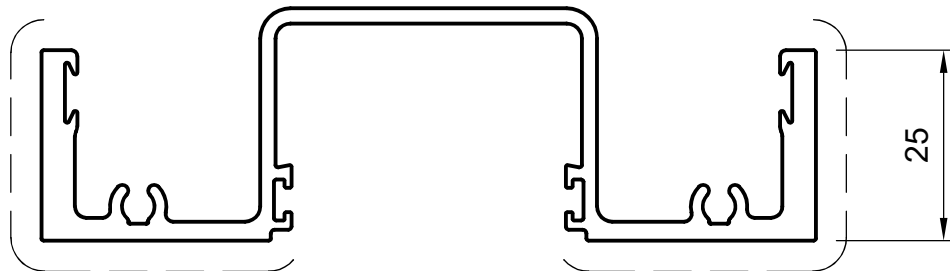
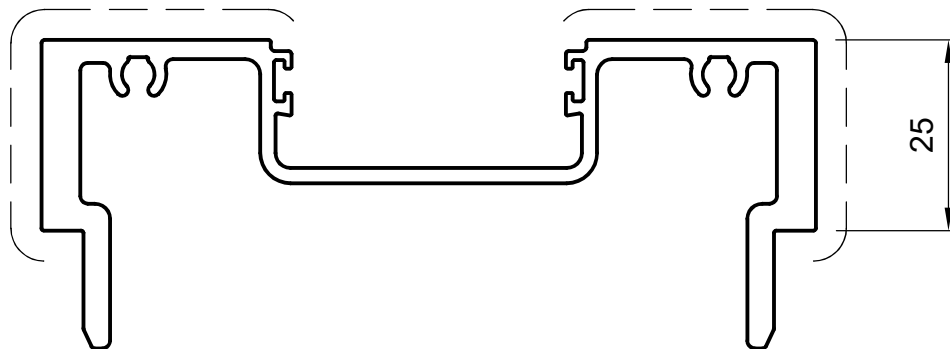

# 101.6mm COMMERCIAL FRAME CENTRE GLAZED - DOUBLE GLAZED

## EXTRUSION PROFILES

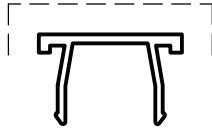

**CF306**  
INFILL

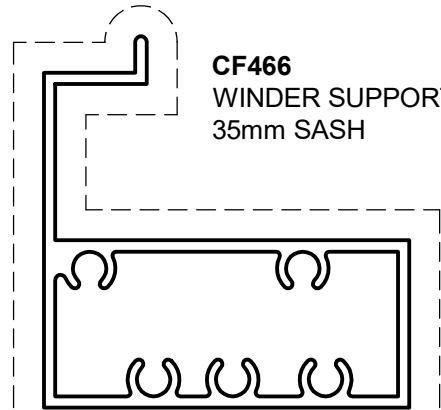

**CF466**  
WINDER SUPPORT  
35mm SASH

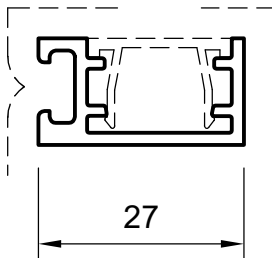

**CF429C**  
PLANT ON DOOR STOP

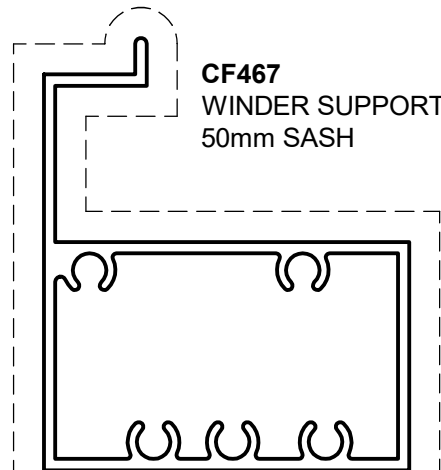

**CF467**  
WINDER SUPPORT  
50mm SASH

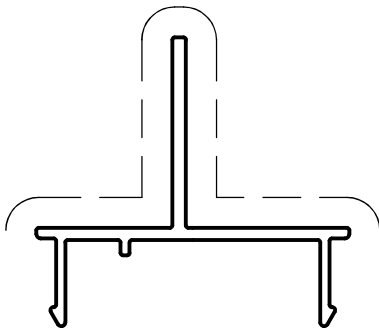

**RC411**  
50mm AWNING STOP - 101.6mm DG

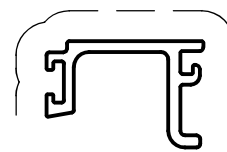

DG POCKET REDUCER

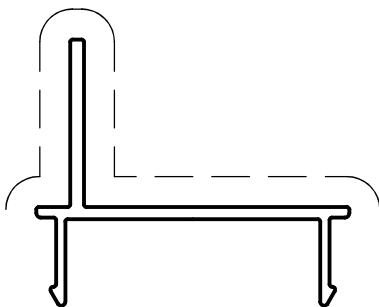

**RC412**  
35mm AWNING STOP - 101.6mm DG

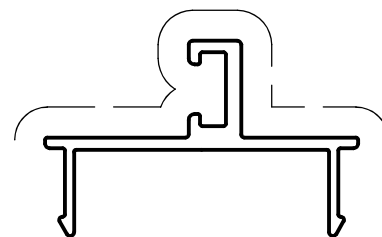

**RC413**  
45mm DOOR STOP - 101.6mm DG

# 101.6mm COMMERCIAL FRAME CENTRE GLAZED - DOUBLE GLAZED

## EXTRUSION PROFILES

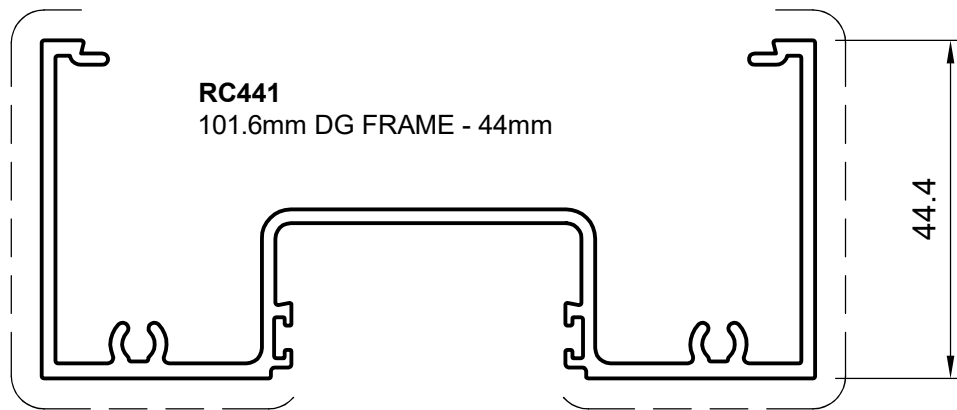

### NOTE:

- Glass cover is reduced to 8mm in the 44mm slimline frame
- The hole pattern matches the 44mm **single-glazed** system, punching is performed using the single-glazed press tool
- There are no 44mm split mullion options, 50mm mullions must be used

RC443  
101.6mm DG BEAD - 44mm

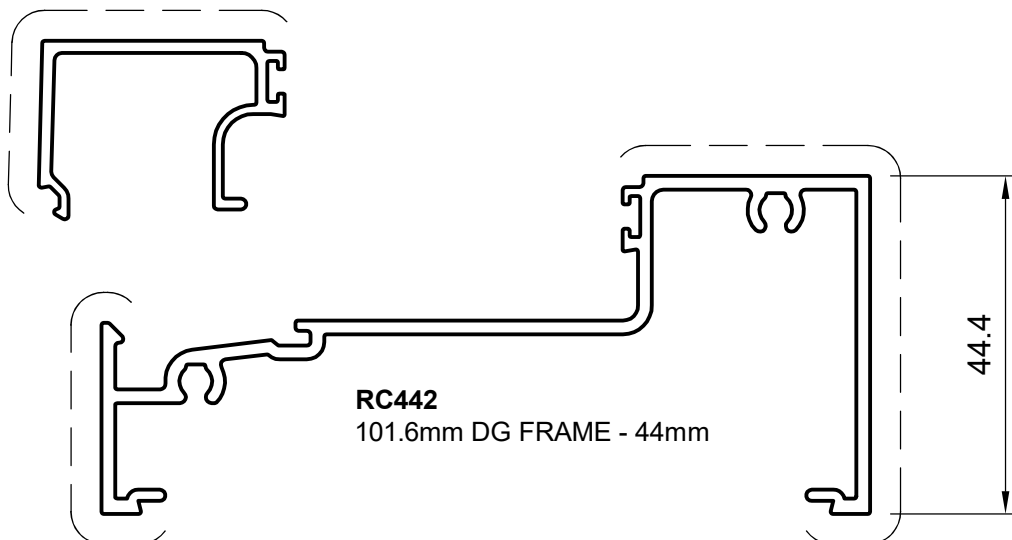

# 101.6mm COMMERCIAL FRAME CENTRE GLAZED - DOUBLE GLAZED

## EXTRUSION PROFILES

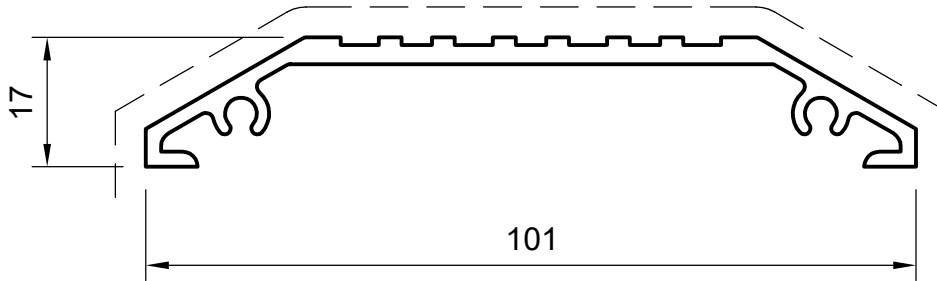

**CF468**  
BEVELLED  
THRESHOLD

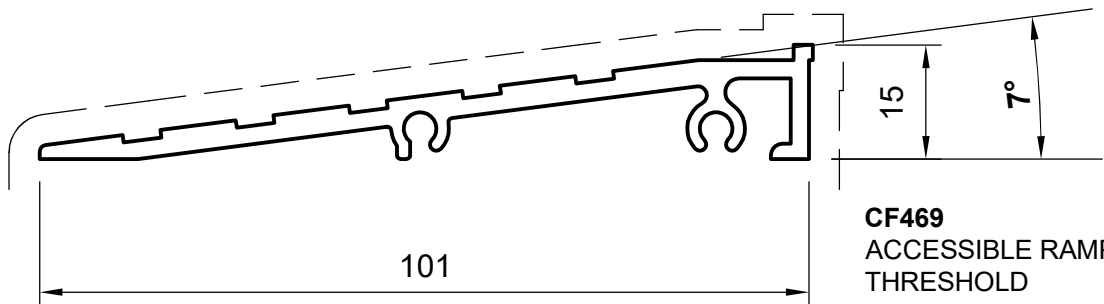

**CF469**  
ACCESSIBLE RAMP  
THRESHOLD

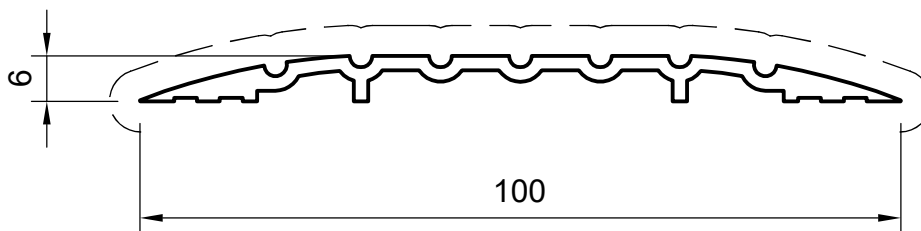

**CF469**  
LOW PROFILE  
THRESHOLD

# 101.6mm COMMERCIAL FRAME CENTRE GLAZED - DOUBLE GLAZED

## EXTRUSION PROFILES

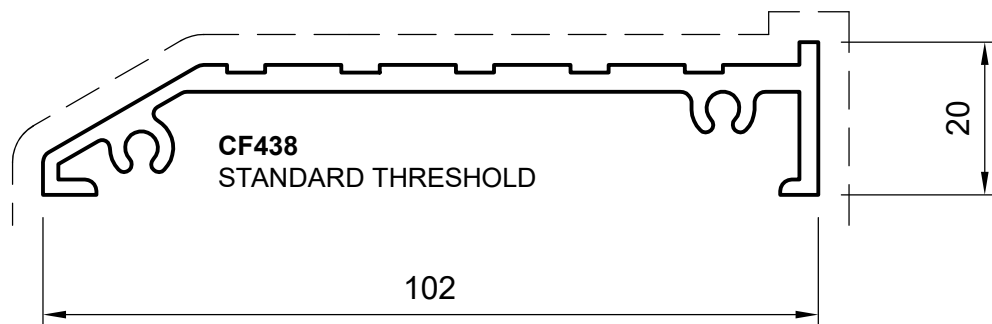
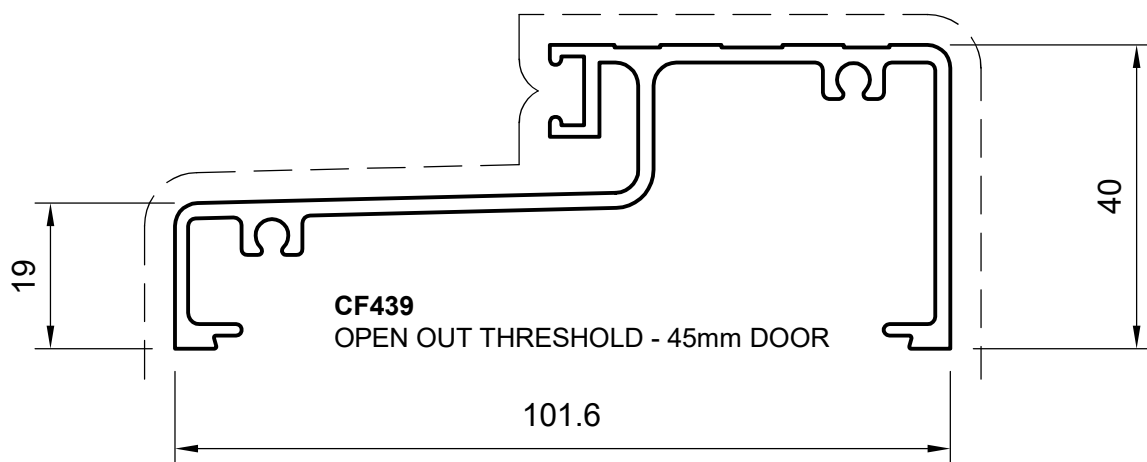
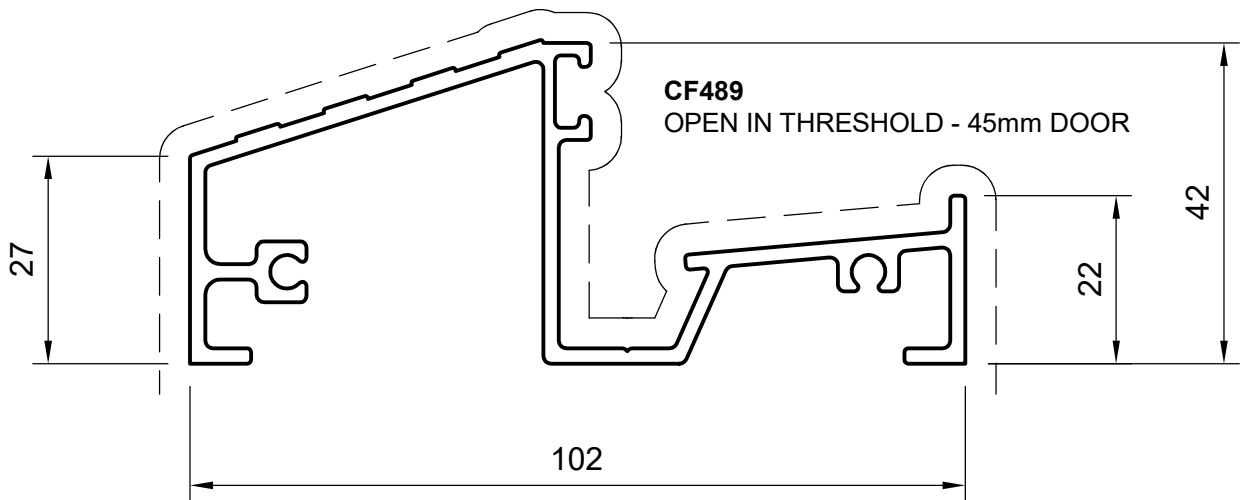

# 101.6mm COMMERCIAL FRAME CENTRE GLAZED - DOUBLE GLAZED EXTRUSION PROFILES

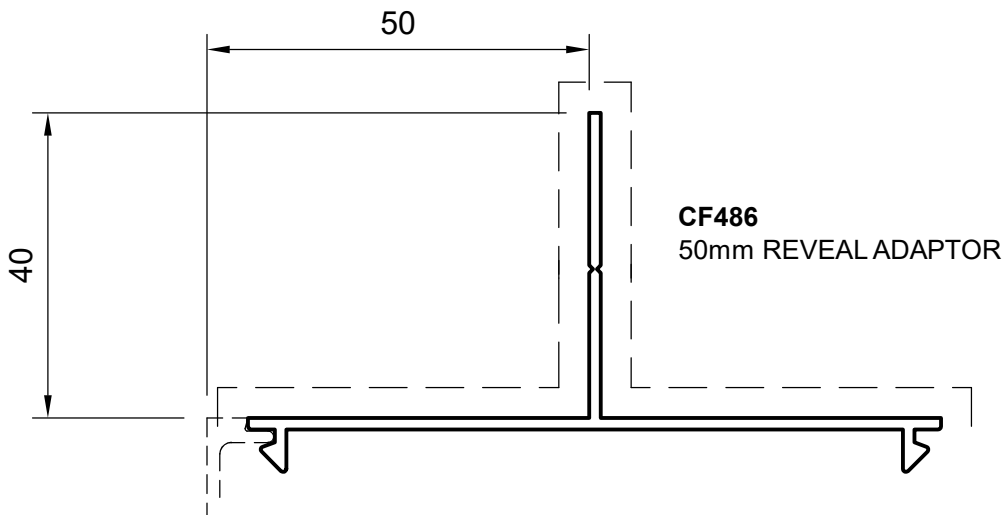
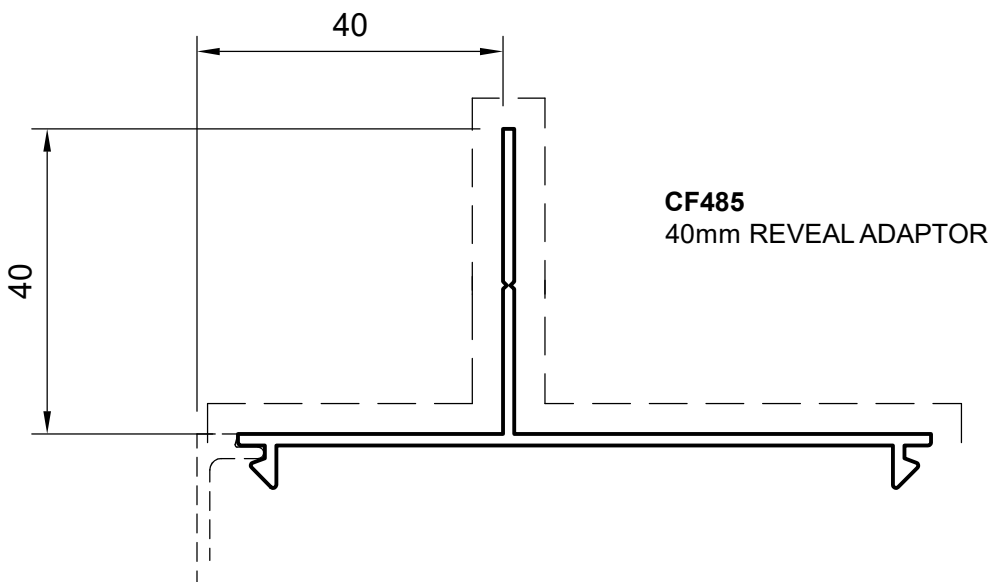
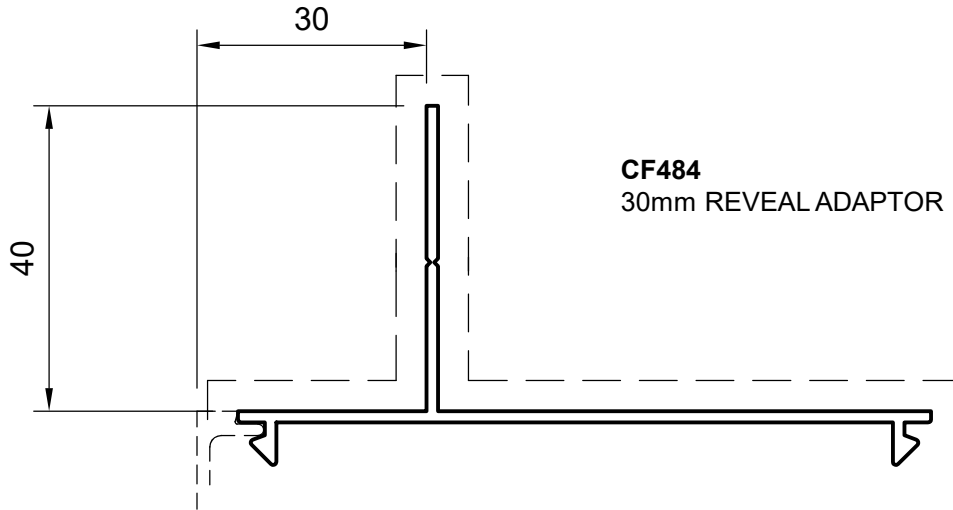

# 101.6mm COMMERCIAL FRAME CENTRE GLAZED - DOUBLE GLAZED EXTRUSION PROFILES

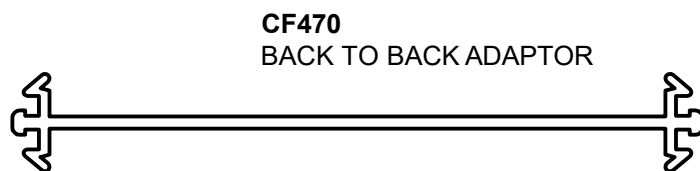
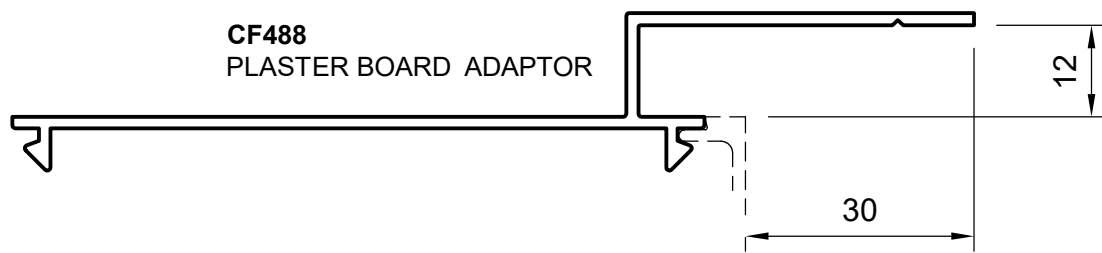
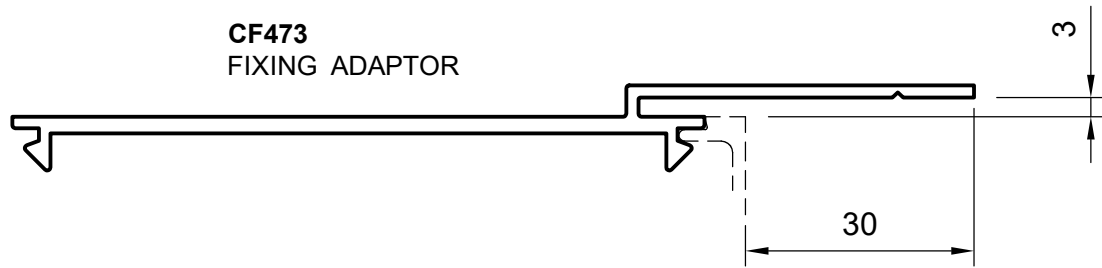

# 101.6mm COMMERCIAL FRAME CENTRE GLAZED - DOUBLE GLAZED

## 100mm SUB SILLS

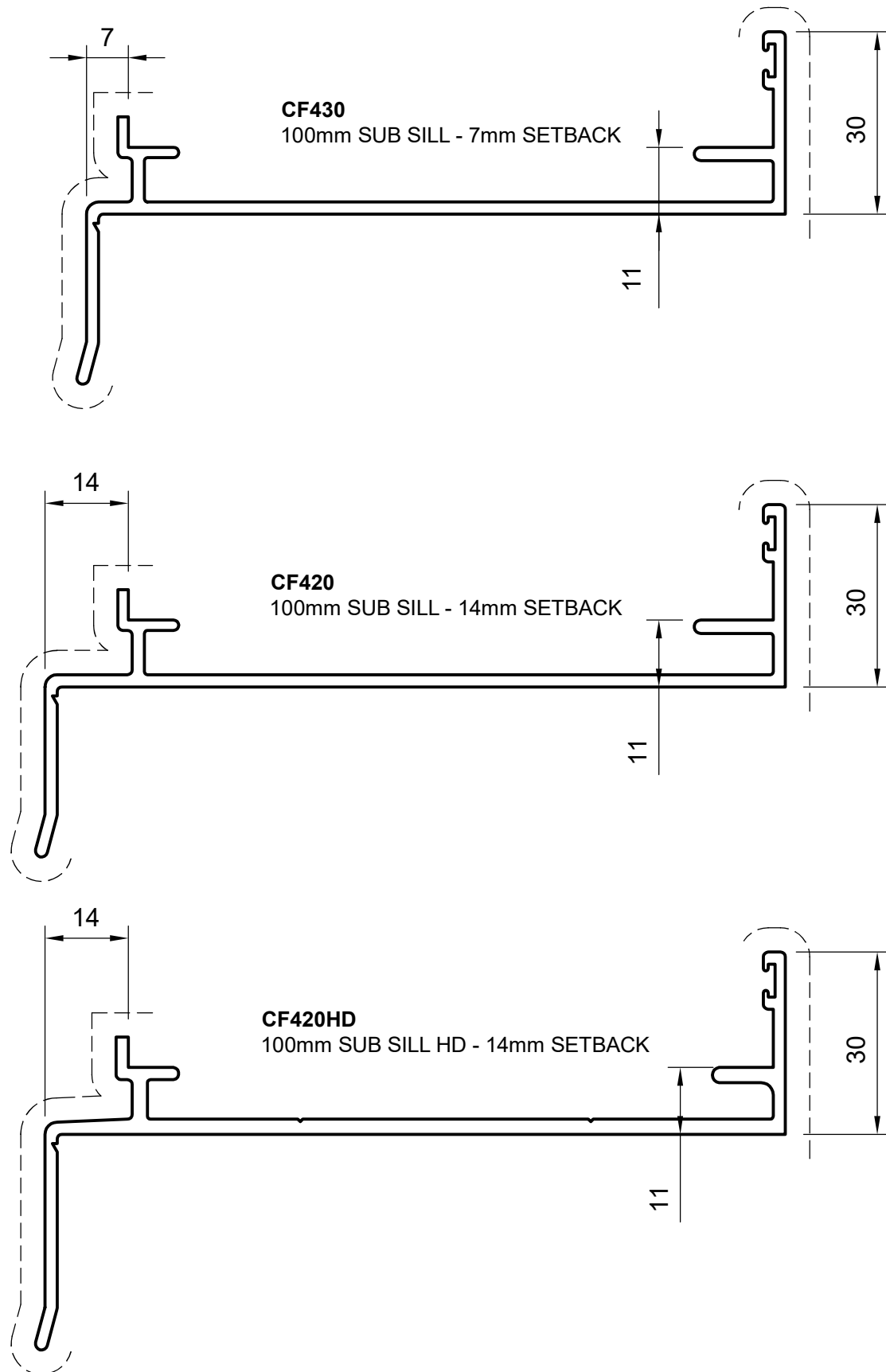

# 101.6mm COMMERCIAL FRAME CENTRE GLAZED - DOUBLE GLAZED

## 100mm SUB SILLS

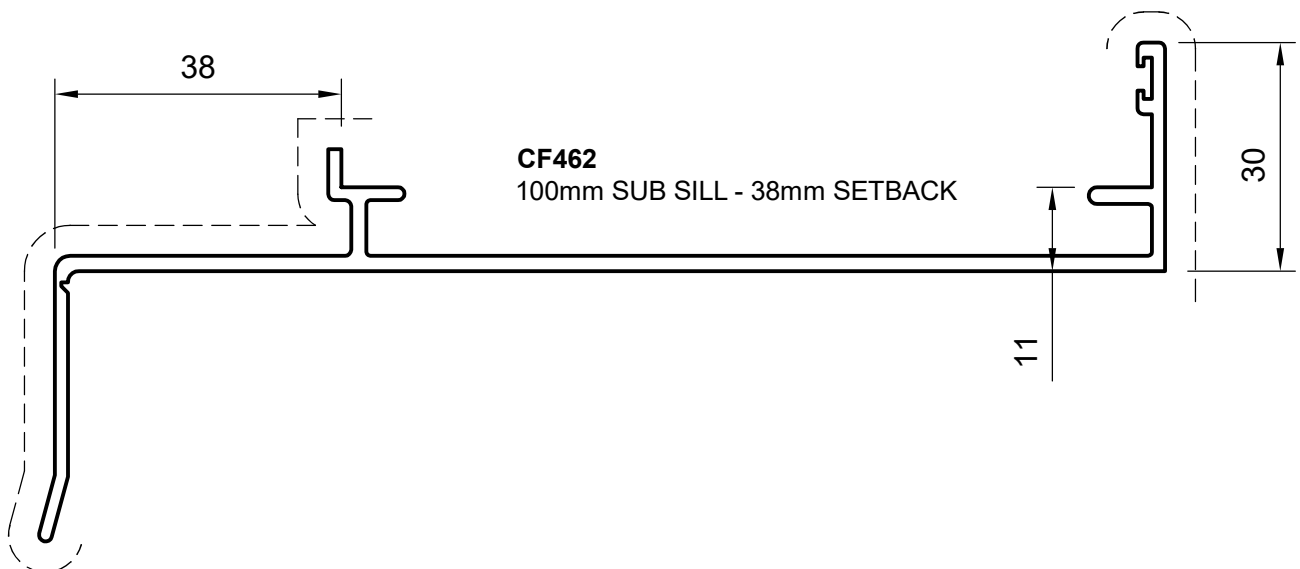
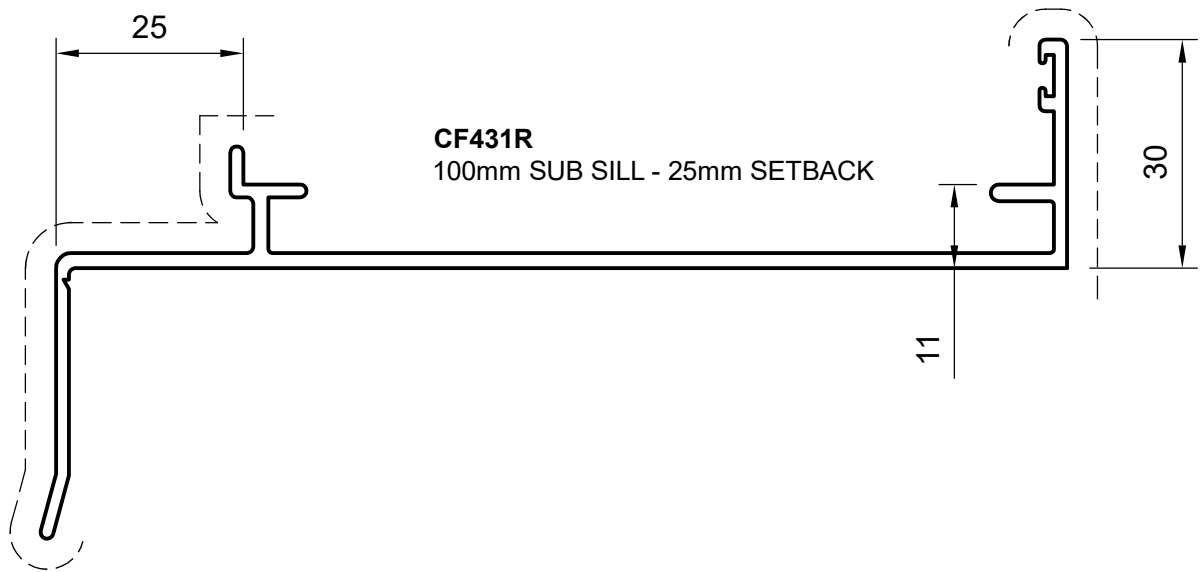

# 101.6mm COMMERCIAL FRAME CENTRE GLAZED - DOUBLE GLAZED

## 100mm SUB HEADS

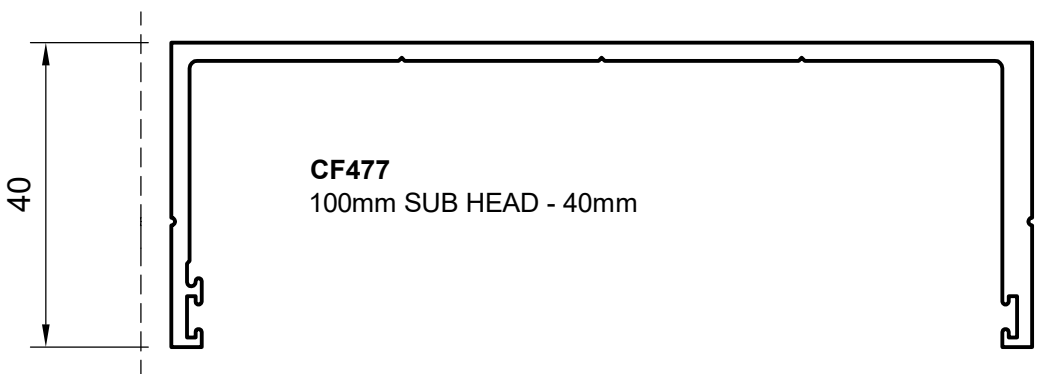
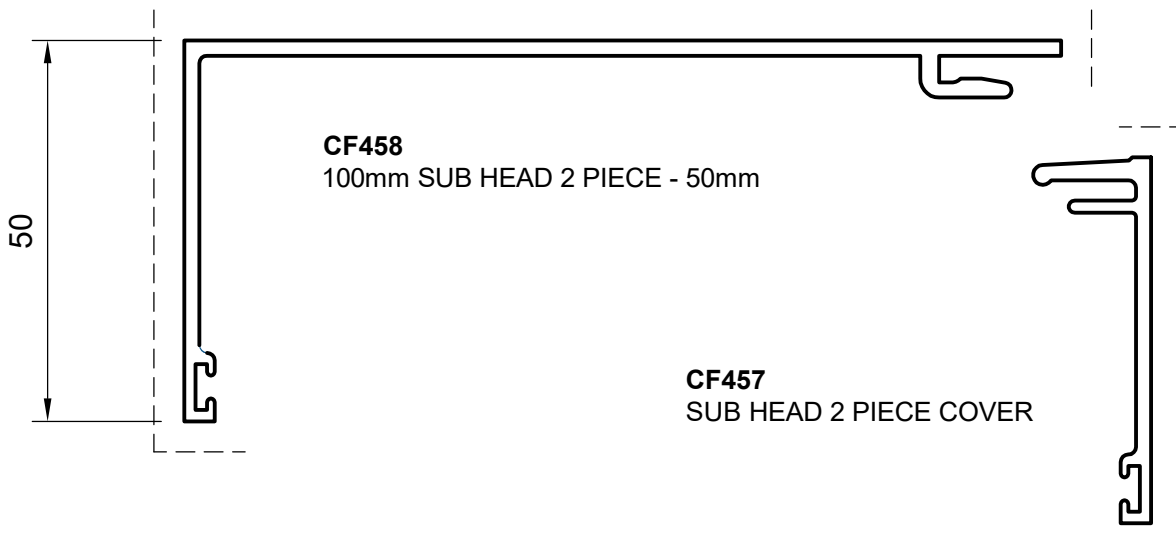
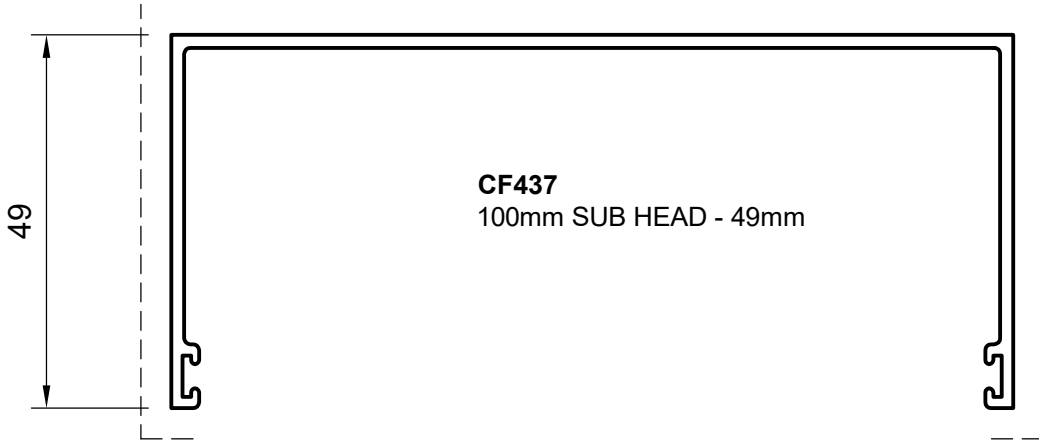

# 101.6mm COMMERCIAL FRAME CENTRE GLAZED - DOUBLE GLAZED

## ACCESSORIES



**CFH204**  
GLAZING WEDGE (4mm GAP)  
100m ROLL



**CFH205**  
GLAZING WEDGE (5mm GAP)  
100m ROLL



**CFH206**  
GLAZING WEDGE (6mm GAP)  
100m ROLL

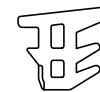

**CFH207**  
GLAZING WEDGE (7mm GAP)  
100m ROLL

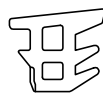

**CFH208**  
GLAZING WEDGE (8mm GAP)  
100m ROLL



**CFH260**  
CAPTIVE WEDGE (6mm GAP)  
100m ROLL

# 101.6mm COMMERCIAL FRAME CENTRE GLAZED - DOUBLE GLAZED

## ACCESSORIES



**CFH220**  
CAPTIVE WEDGE (2mm GAP)  
200m ROLL



**CFH5**  
MULLION SEAL  
200m ROLL



**CFH13**  
SASH SEAL  
200m ROLL

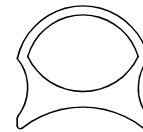

**CFH4**  
DOOR BUFFER  
200m ROLL

# 101.6mm COMMERCIAL FRAME CENTRE GLAZED - DOUBLE GLAZED CONFIGURATIONS

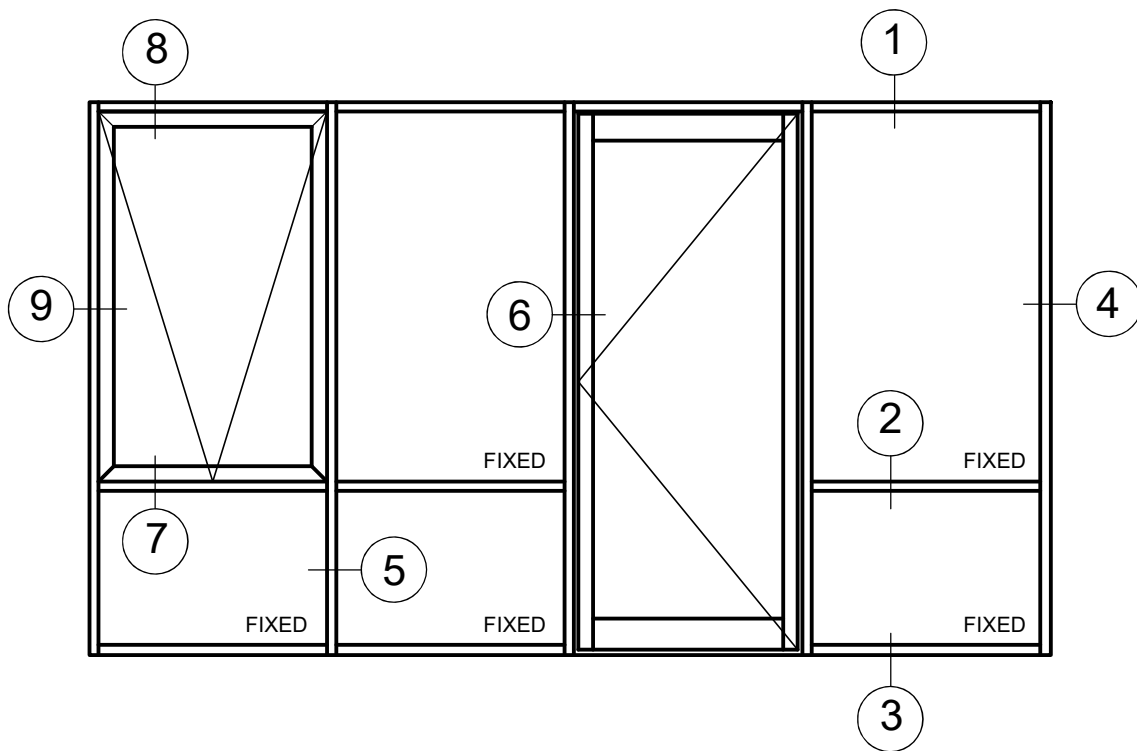

# 101.6mm COMMERCIAL FRAME CENTRE GLAZED - DOUBLE GLAZED

HEAD / SILL / TRANSOM - 50mm

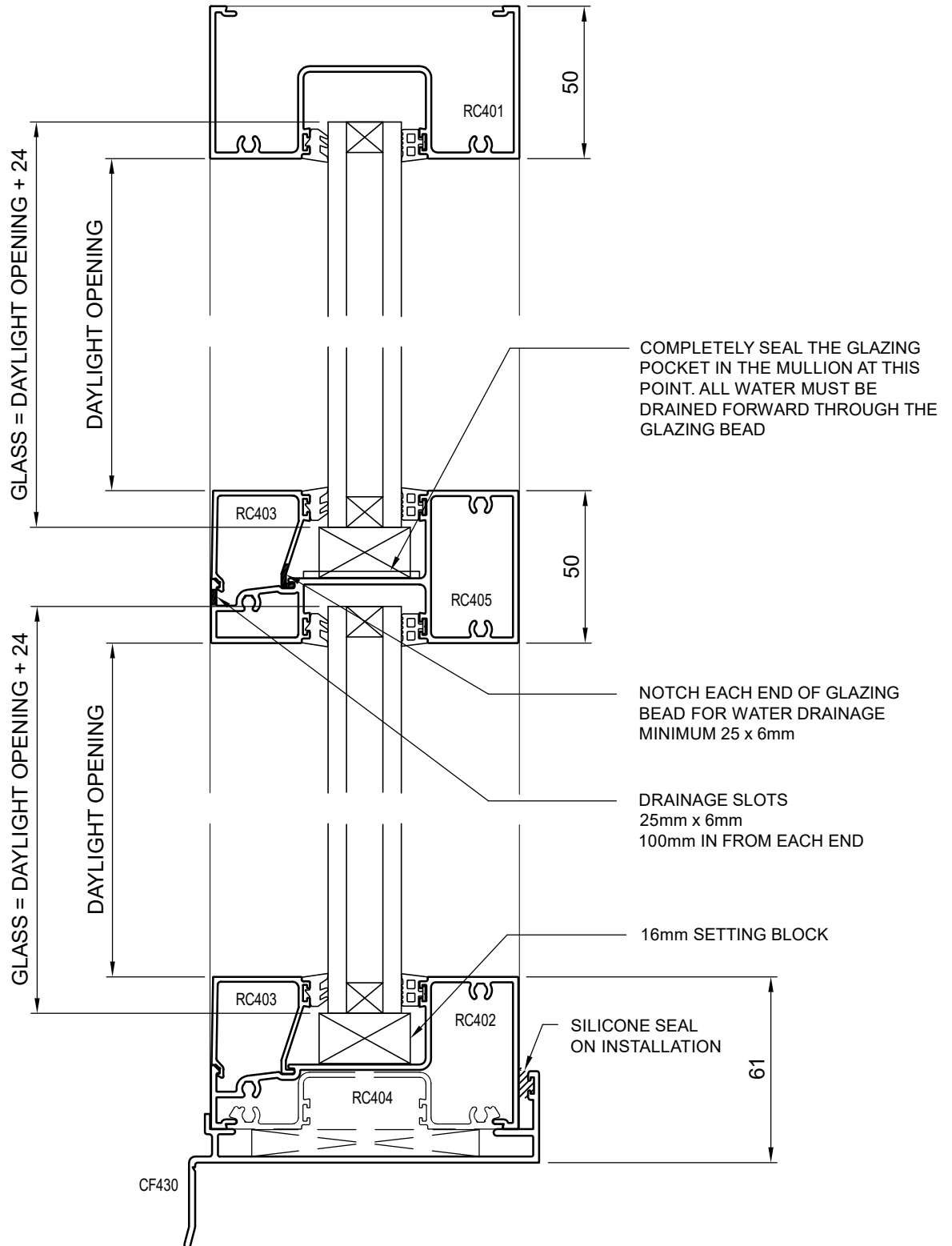

**NOTE:**

- ALL JOINTS TO BE SEALED USING A SUITABLE SMALL JOINT SEALANT OR CLOSED CELL FRAME GASKET

# 101.6mm COMMERCIAL FRAME CENTRE GLAZED - DOUBLE GLAZED

## JAMB / MULLION

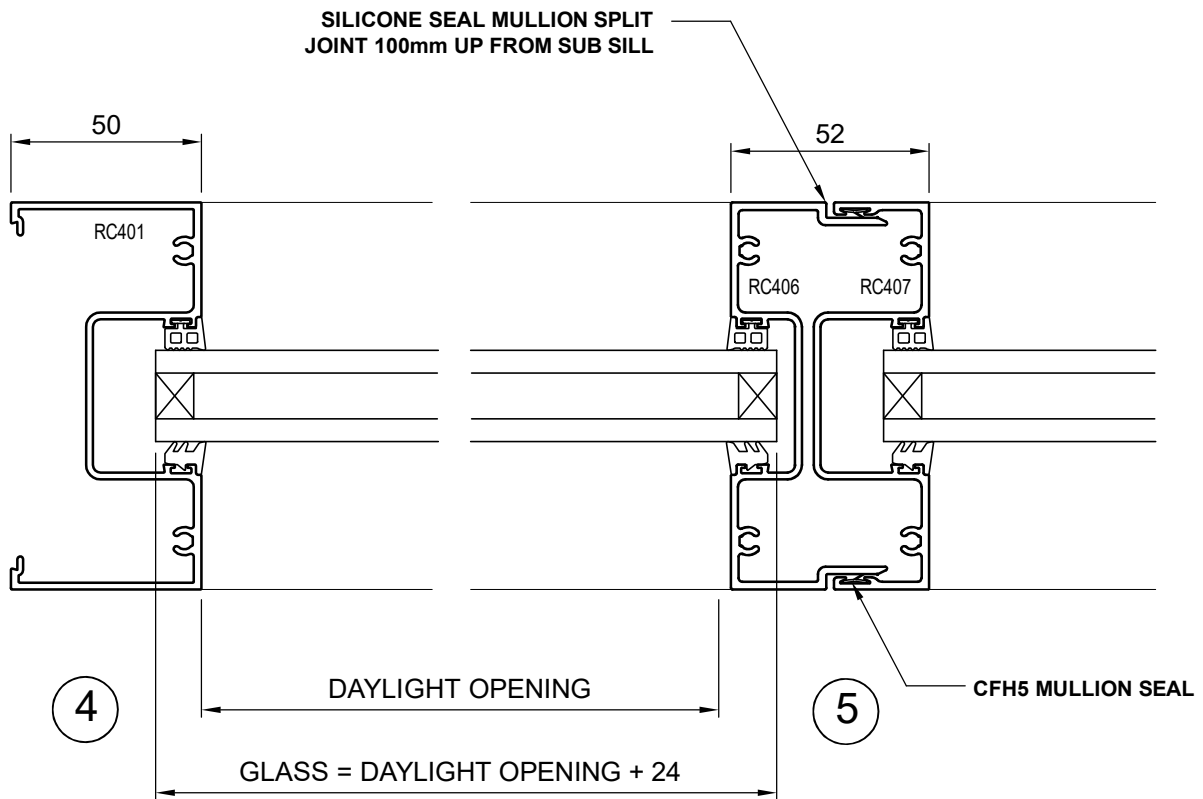

## MULLION OPTIONS

STD SPLIT MULLION

HEAVY DUYT SPLIT MULLION

COUPLED MULLION

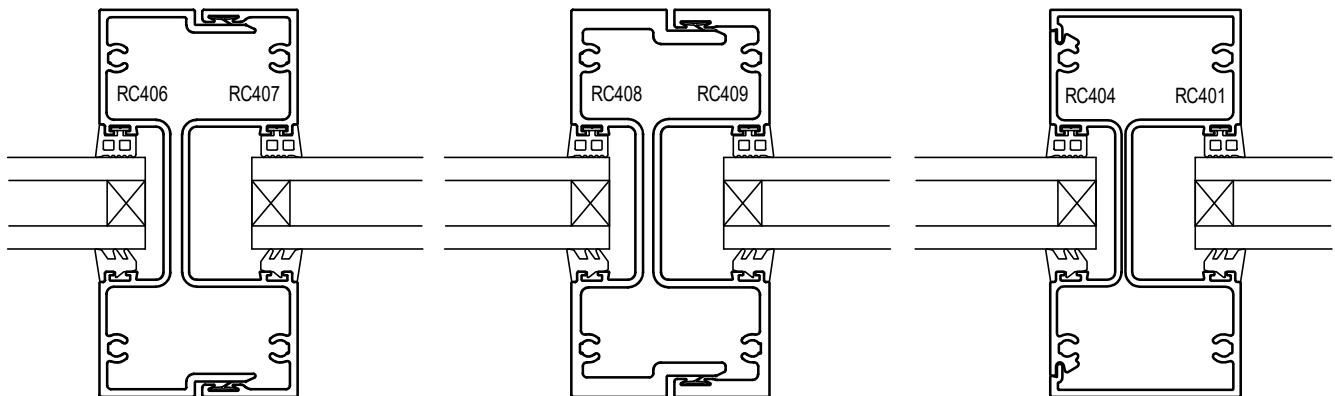

NOTE:

- ALL JOINTS TO BE SEALED USING A SUITABLE SMALL JOINT SEALANT OR CLOSED CELL FRAME GASKET

# 101.6mm COMMERCIAL FRAME CENTRE GLAZED - DOUBLE GLAZED

## HORIZONTAL DETAIL - 45mm HINGED DOOR JAMB - OPEN OUT

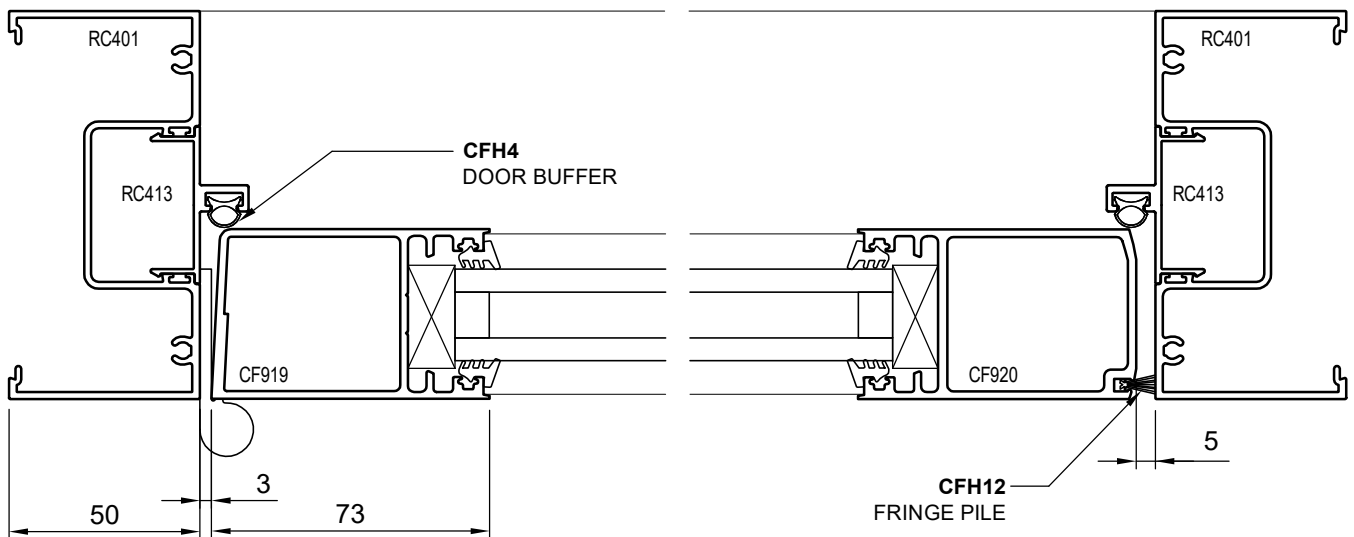

**NOTE:**

- ALL JOINTS TO BE SEALED USING A SUITABLE SMALL JOINT SEALANT OR CLOSED CELL FRAME GASKET

# 101.6mm COMMERCIAL FRAME CENTRE GLAZED - DOUBLE GLAZED

HEAD / SILL / TRANSOM - 44mm

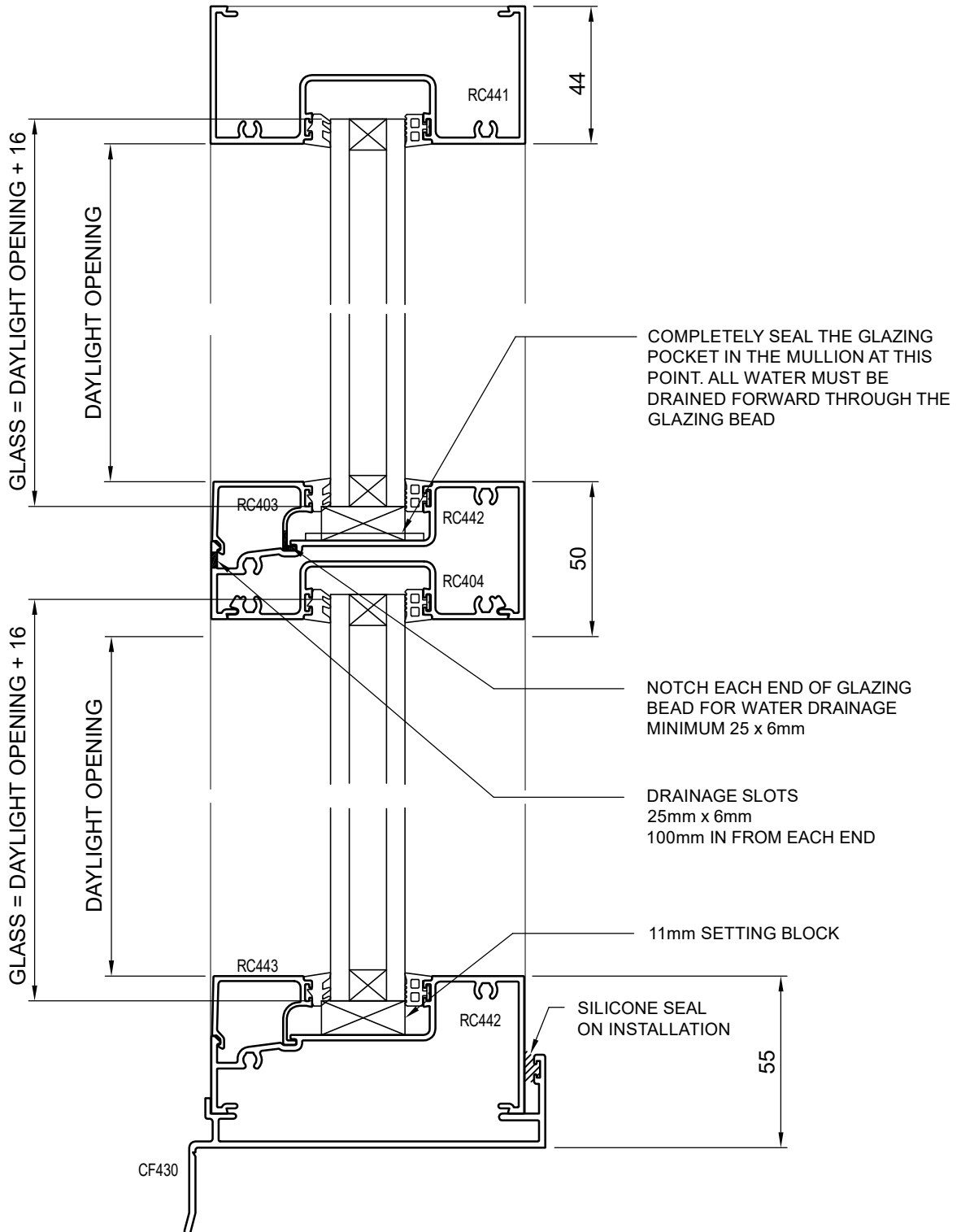

**NOTE:**

- ALL JOINTS TO BE SEALED USING A SUITABLE SMALL JOINT SEALANT OR CLOSED CELL FRAME GASKET

# 101.6mm COMMERCIAL FRAME CENTRE GLAZED - DOUBLE GLAZED

## VERTICAL DETAIL - 45mm HINGED DOOR - OPEN OUT

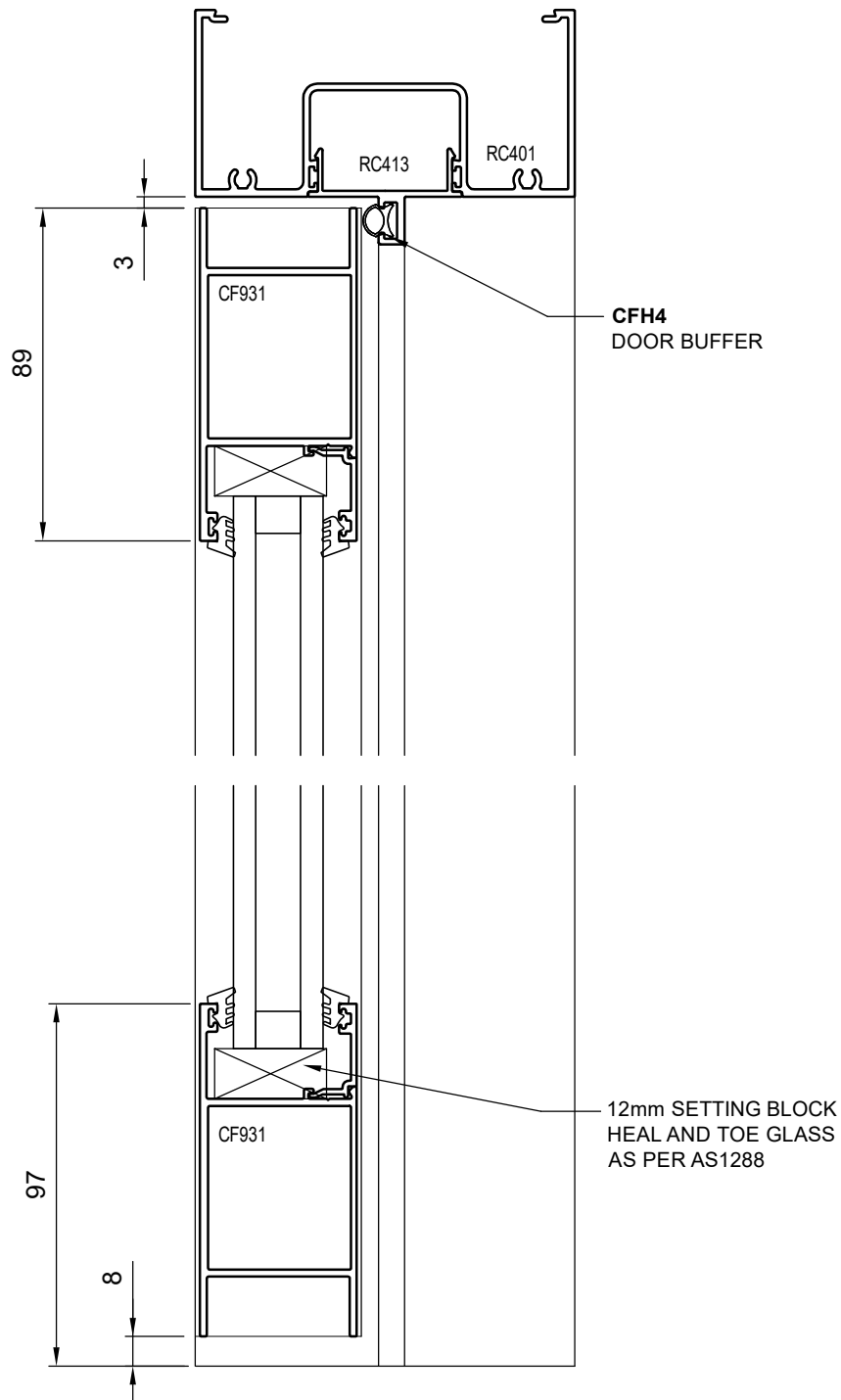

**NOTE:**

- ALL JOINTS TO BE SEALED USING A SUITABLE SMALL JOINT SEALANT OR CLOSED CELL FRAME GASKET

# 101.6mm COMMERCIAL FRAME CENTRE GLAZED - DOUBLE GLAZED

## VERTICAL DETAIL - 35mm AWNING

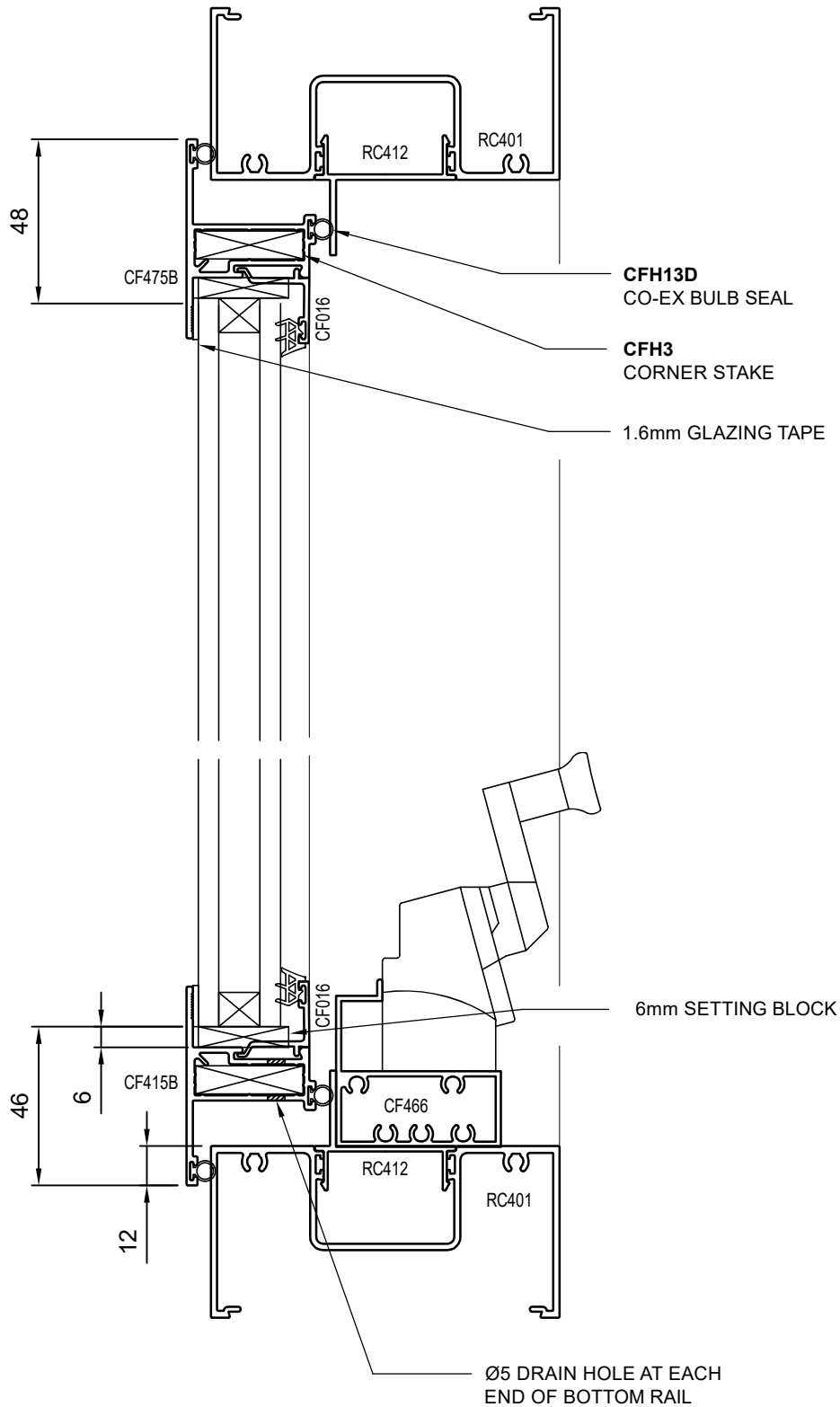

**NOTE:**

- ALL JOINTS TO BE SEALED USING A SUITABLE SMALL JOINT SEALANT OR CLOSED CELL FRAME GASKET

# 101.6mm COMMERCIAL FRAME CENTRE GLAZED - DOUBLE GLAZED HORIZONTAL DETAIL - 35mm AWNING

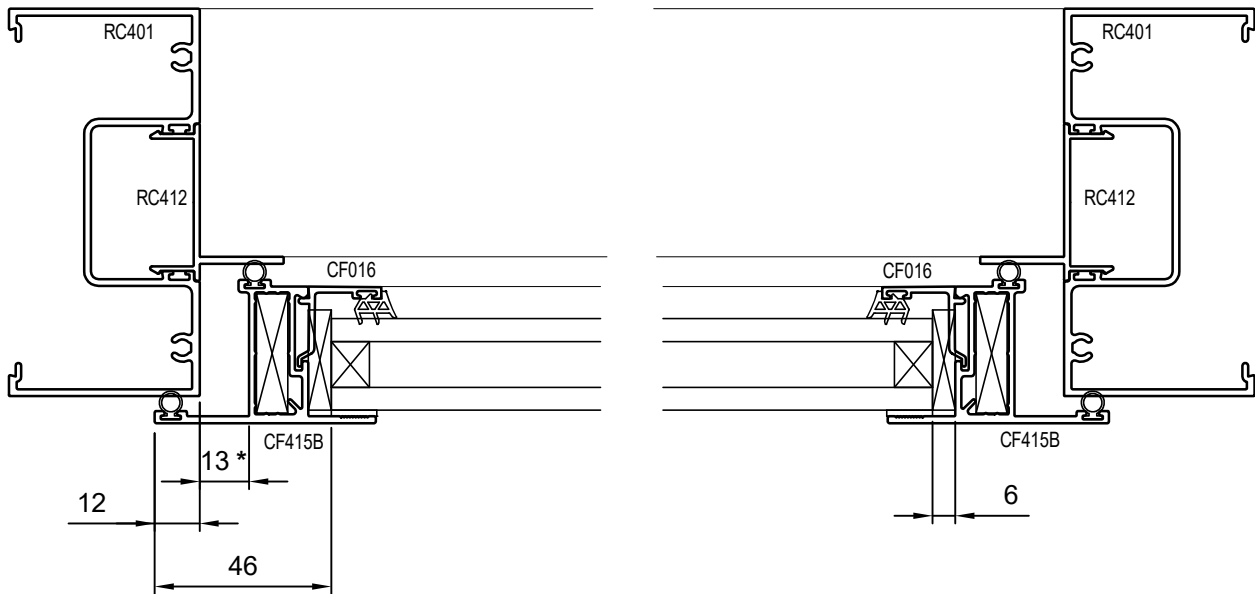

**NOTE:**

- ALL JOINTS TO BE SEALED USING A SUITABLE SMALL JOINT SEALANT OR CLOSED CELL FRAME GASKET

# 101.6mm COMMERCIAL FRAME CENTRE GLAZED - DOUBLE GLAZED

## VERTICAL DETAIL - 50mm AWNING

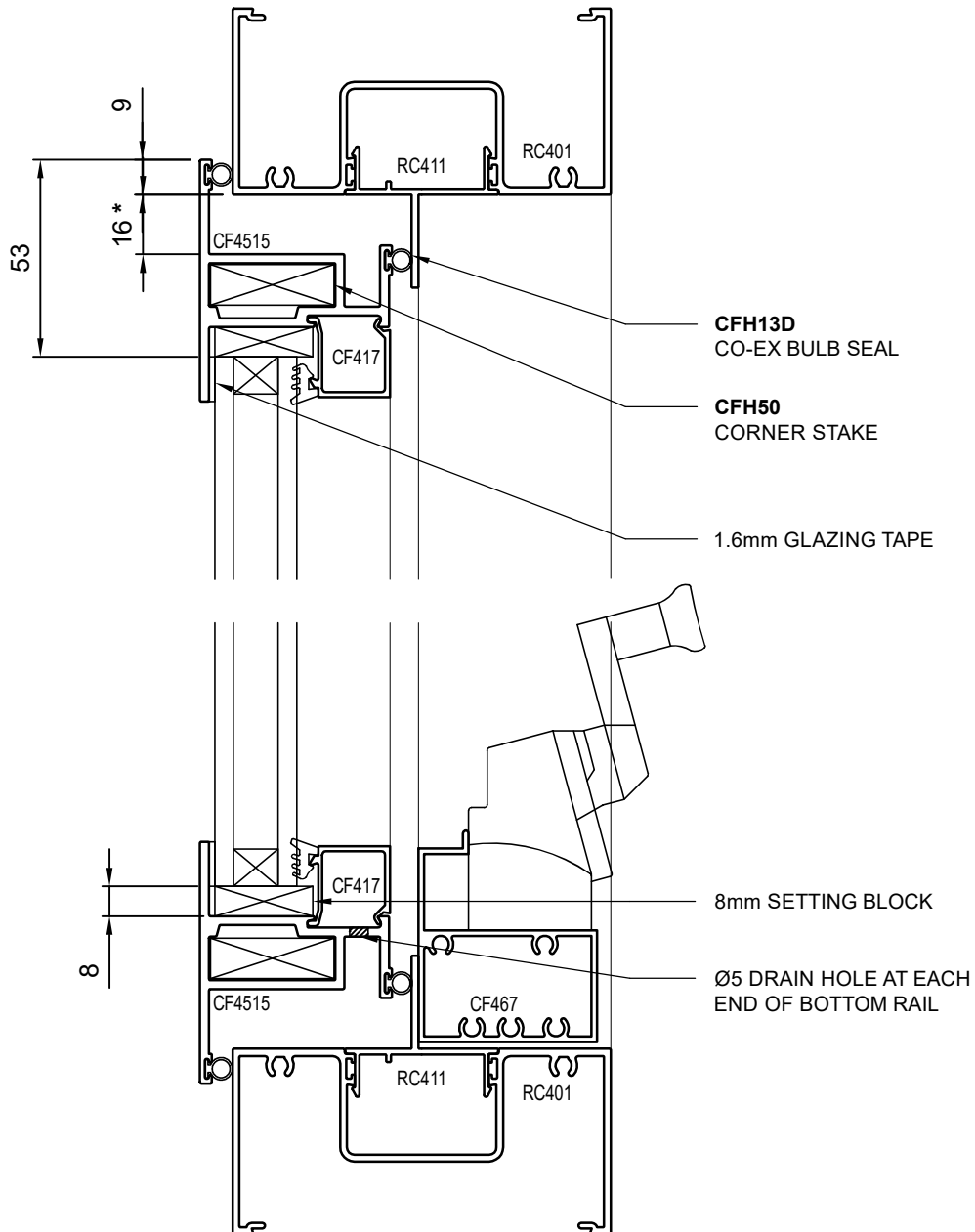

**NOTE:**

- ALL JOINTS TO BE SEALED USING A SUITABLE SMALL JOINT SEALANT OR CLOSED CELL FRAME GASKET

# 101.6mm COMMERCIAL FRAME CENTRE GLAZED - DOUBLE GLAZED HORIZONTAL DETAIL - 50mm AWNING

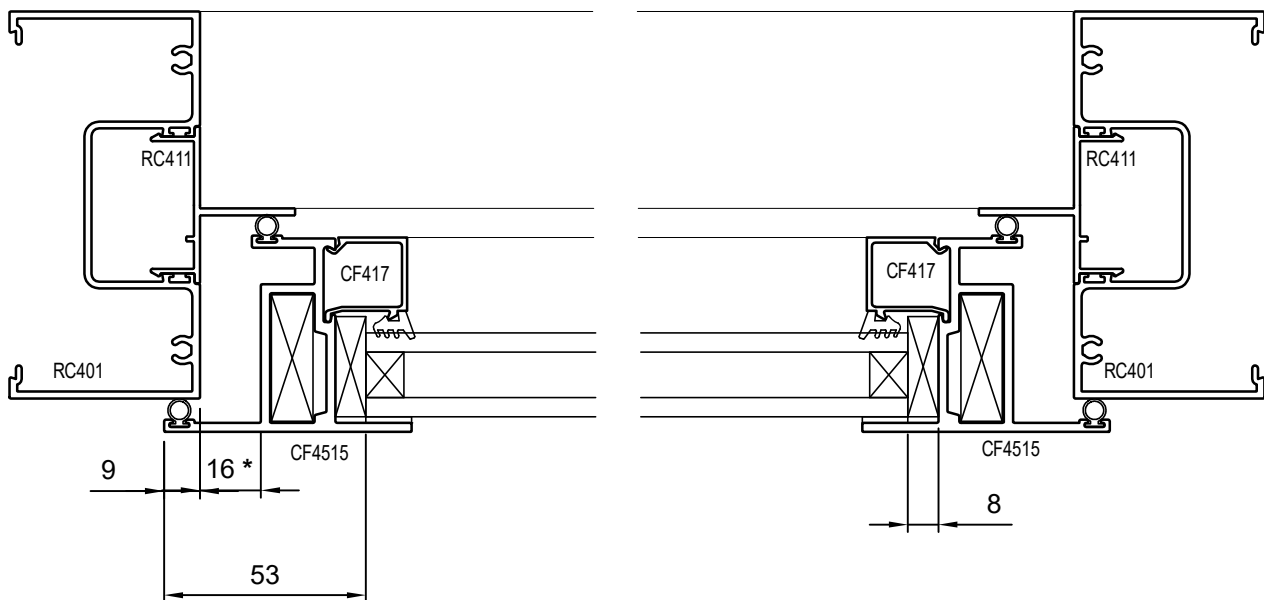

**NOTE:**

- ALL JOINTS TO BE SEALED USING A SUITABLE SMALL JOINT SEALANT OR CLOSED CELL FRAME GASKET

# 101.6mm COMMERCIAL FRAME CENTRE GLAZED - DOUBLE GLAZED MACHINING - JAMB ASSEMBLY HOLES - 50mm

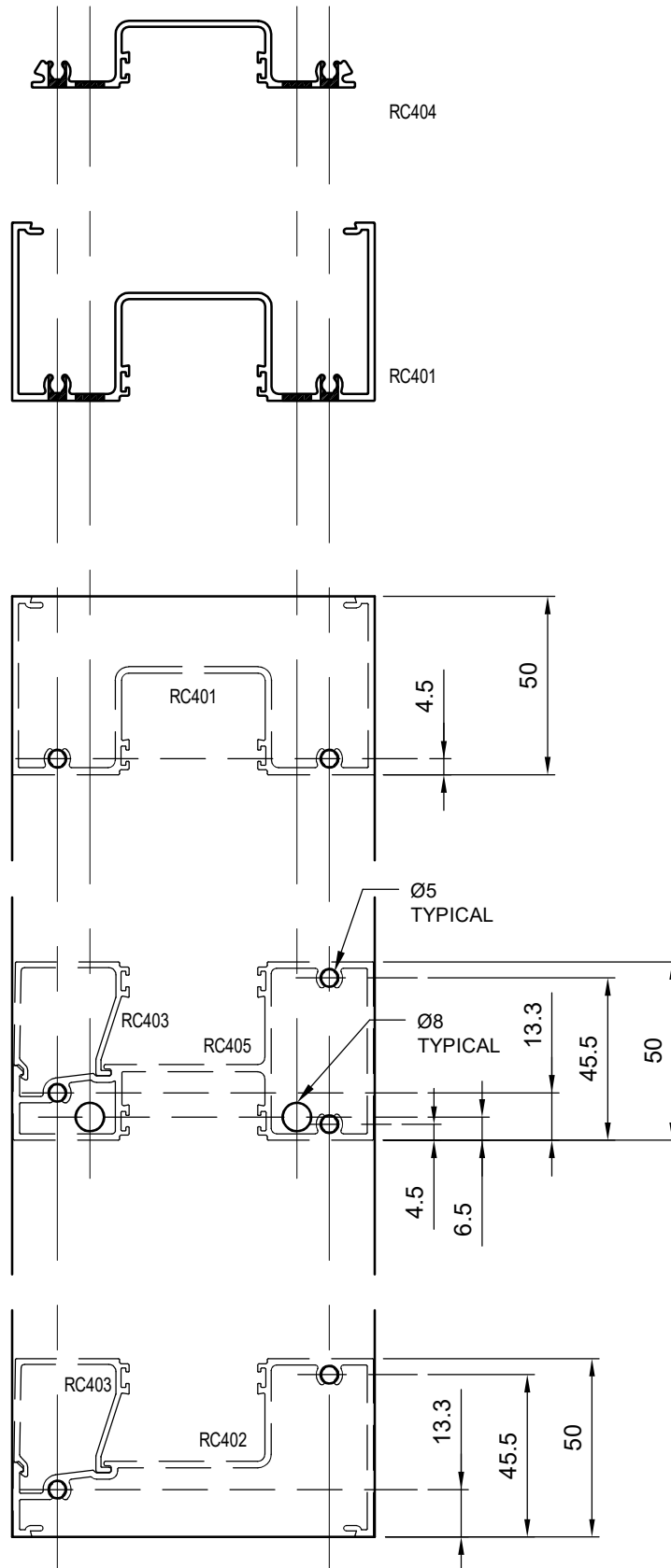

# 101.6mm COMMERCIAL FRAME CENTRE GLAZED - DOUBLE GLAZED

## MACHINING - JAMB ASSEMBLY HOLES - 50mm

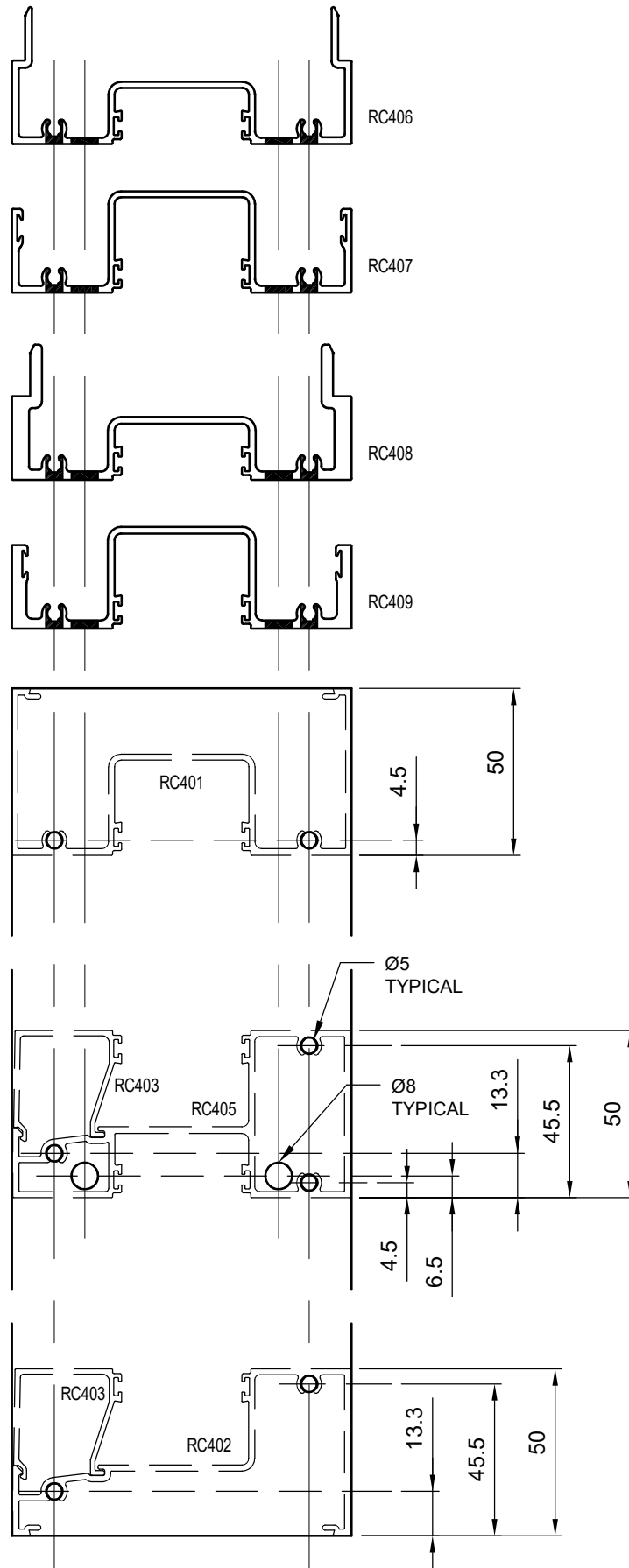

# 101.6mm COMMERCIAL FRAME CENTRE GLAZED - DOUBLE GLAZED

## MACHINING - JAMB ASSEMBLY HOLES - 44mm (SINGLE GLAZED HOLE PATTERN)

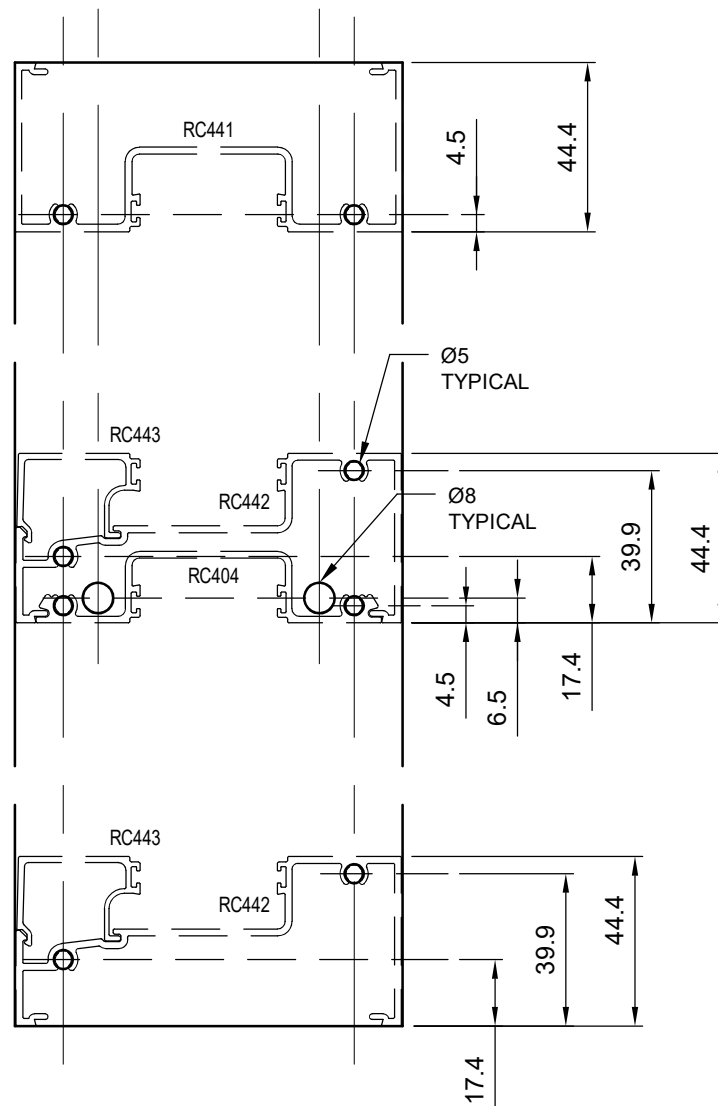
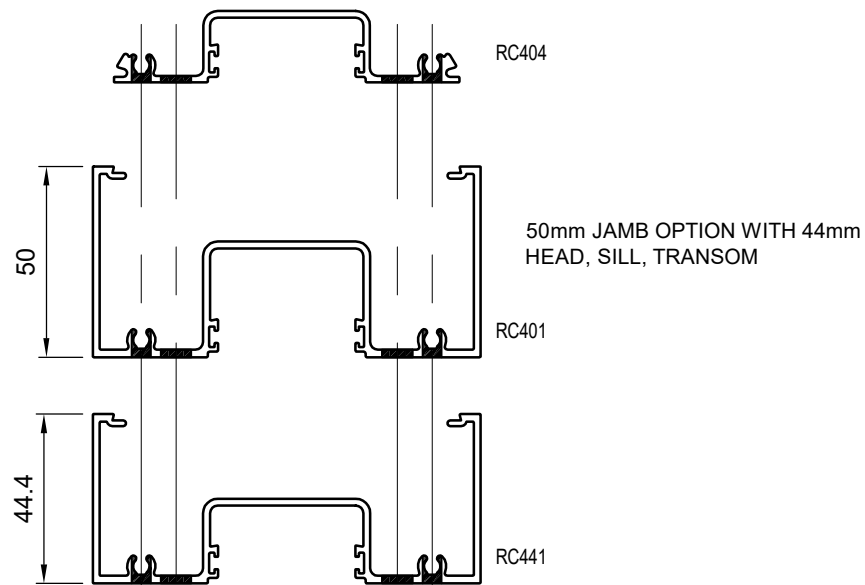

# 101.6mm COMMERCIAL FRAME CENTRE GLAZED - DOUBLE GLAZED

## MACHINING - JAMB ASSEMBLY HOLES - 44mm (SINGLE GLAZED HOLE PATTERN)

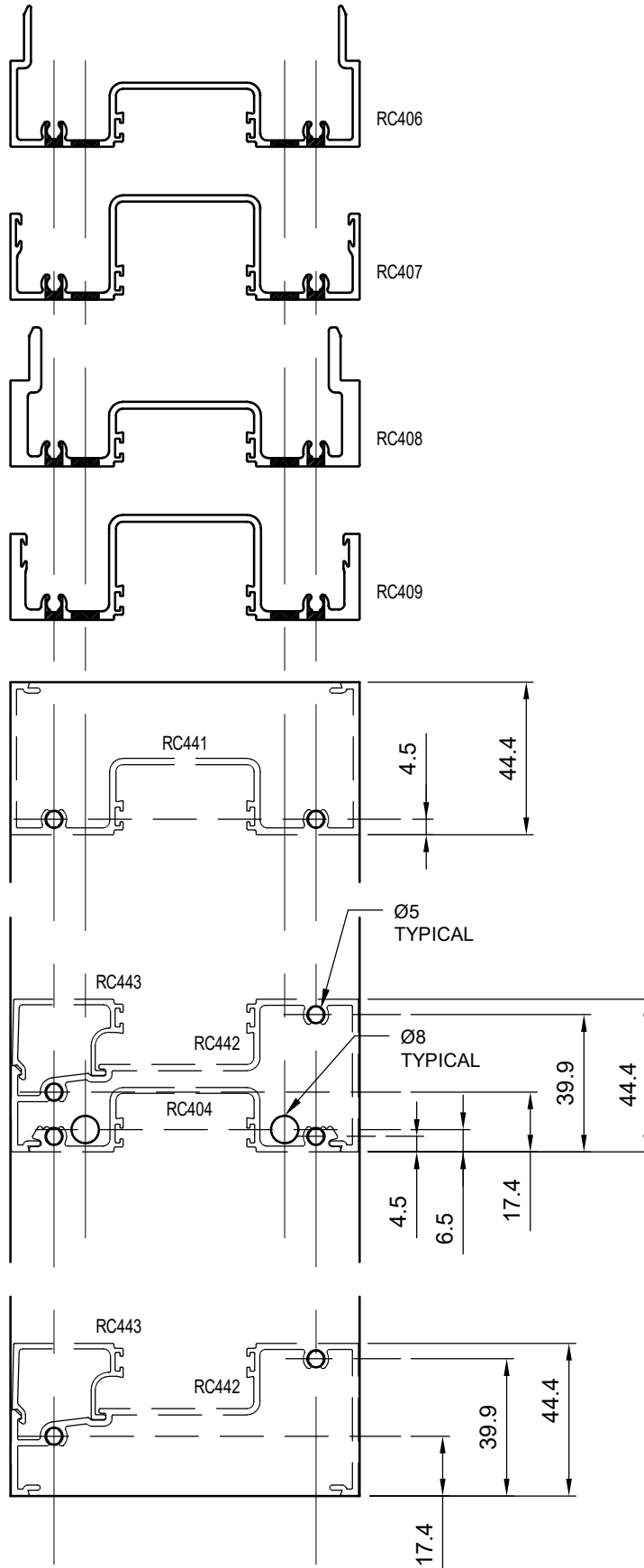

# 101.6mm COMMERCIAL FRAME CENTRE GLAZED - DOUBLE GLAZED

## GLAZING DETAILS - CAPTIVE

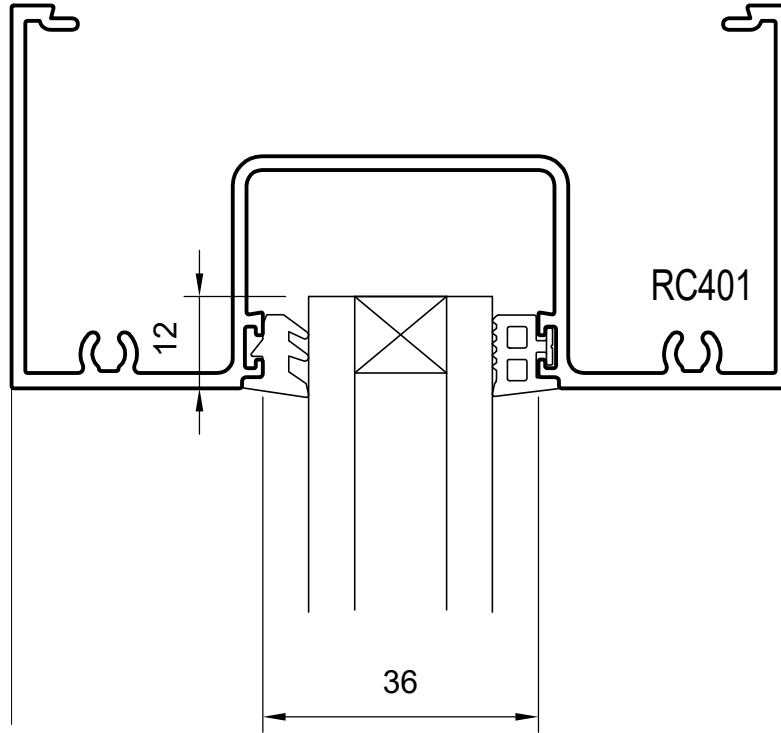

SINGLE GLAZE - CAPTIVE		
GLASS THICKNESS	WEDGE	CAPTIVE
22mm	CFH208 - 8mm	CFH260 - 6mm
24mm	CFH206 - 6mm	CFH260 - 6mm
25mm	CFH205 - 5mm	CFH260 - 6mm
26mm	CFH204 - 4mm	CFH260 - 6mm
28mm	CFH206 - 6mm	CFH220 - 2mm
30mm	CFH204 - 4mm	CFH220 - 2mm

# 101.6mm COMMERCIAL FRAME CENTRE GLAZED - DOUBLE GLAZED

## SUB SILL END DAM SEALING

LAY A BED OF SILICONE ACROSS THE BASE OF THE SUB SILLS, CAREFULLY SEALING INTO THE CORNERS AND UP THE VERTICAL SUB SILL LEGS

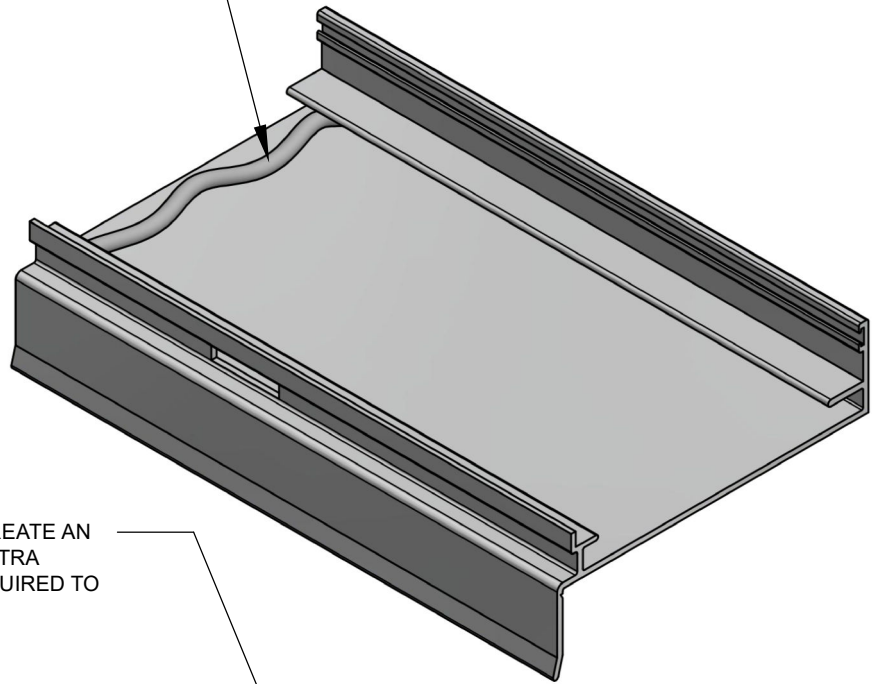

INSTALL A 25 x 25mm ANGLE TO CREATE AN END DAM IN THE SUB SILL. ADD EXTRA SILICONE IN THE CORNERS IF REQUIRED TO ENSURE WATER TIGHTNESS

RIVET ANGLE TO SUB SILL TO ENSURE THE SILICONE SEAL IS NOT DISTURBED OR BROKEN

