

TECHNICAL MANUAL

SUB HEADS & SUB SILLS

COPYRIGHT

This Technical manual remains the property of Rapid Aluminium and contains privileged information which is the subject of copyright and the manual or any part thereof may not be reproduced, copied or loaned in any form without the written permission of Rapid Aluminium Trading P/L. This manual is to be returned to Rapid Aluminium when requested.

DISCLAIMER

Whilst every effort and utmost care has been made to ensure the technical details contained within this manual are accurate, Rapid Aluminium can take no responsibility for any loss or damage whatsoever arising as a result of any errors contained in this manual. This is merely a guideline for fabrication and assembly purposes. Also, interpretation of standards or codes within this manual is Rapid Aluminium's interpretation for such codes. Responsibility for code compliance remains with the user of this manual. In some cases product dimensions may vary or be changed without notice. The user of this manual should not act or rely upon on any information contained in this manual without first obtaining appropriate professional advice relating to their particular circumstances. Rapid Aluminium Trading P/L disclaims all liability for loss or damage suffered by any party who acts or fails to act in reliance of this manual.

RAPID ALUMINIUM GENERAL WARRANTY

No warranty, condition or term applies to the supply by Rapid Aluminium of products and their components manufactured by it unless it is set out in this Condition or is implied by law and cannot be excluded. If any term is implied into this Condition by law, and it would be illegal for Rapid Aluminium to exclude it, then so far as the law allows, the liability of Rapid Aluminium for breach of that term is limited to the cost of repair or replacement (at Rapid's option) of any product or component manufactured by it that Rapid Aluminium determines is defective in materials under normal use and service. Rapid Aluminium is not liable for any other direct or indirect cost, loss or damage to person or property, or for any consequential losses, including cartage and installation. While any product or component is in the custody of Rapid Aluminium for investigation or repair it will be at the risk of the purchaser and Rapid Aluminium or its employees or agents will not be liable for any damage to it. Rapid Aluminium is not liable to the purchaser unless the purchaser notifies Rapid Aluminium in writing immediately on it becoming aware of the alleged defect, and in any event no later than 30 days after the date of delivery. Rapid Aluminium is not liable for any product or component that is not manufactured by it, but Rapid will use its reasonable endeavors to obtain for the purchaser the benefit of any applicable manufacturer's warranty.

SUB HEADS & SUB SILLS

CONTENTS

1 EXTRUSIONS

1.1 - 1.10 Extrusion profiles

2 DETAILS

2.1 Sub Sill Sealing details

2.2 Sub head details

SUB HEADS & SUB SILLS

76mm SUB FRAMES

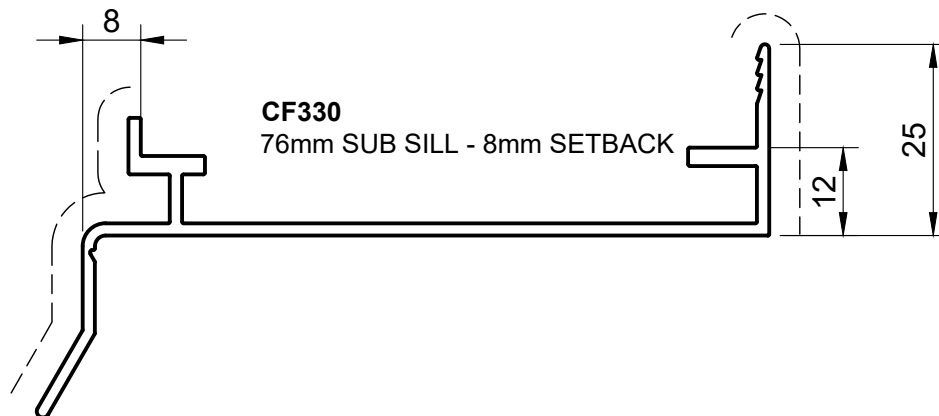
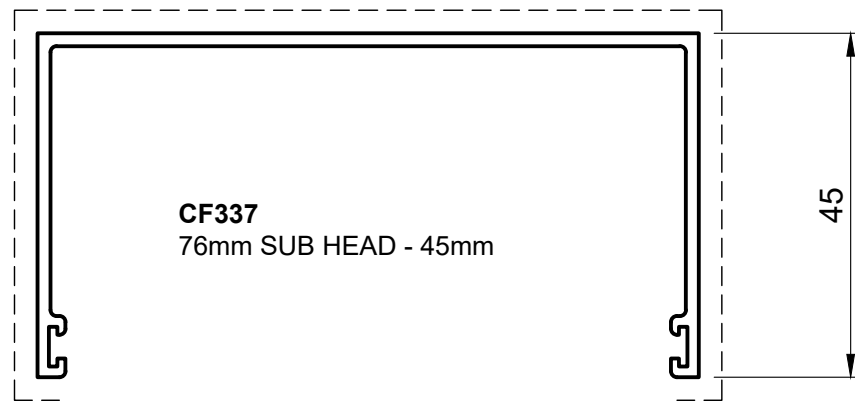

SUB HEADS & SUB SILLS

100mm SUB SILLS

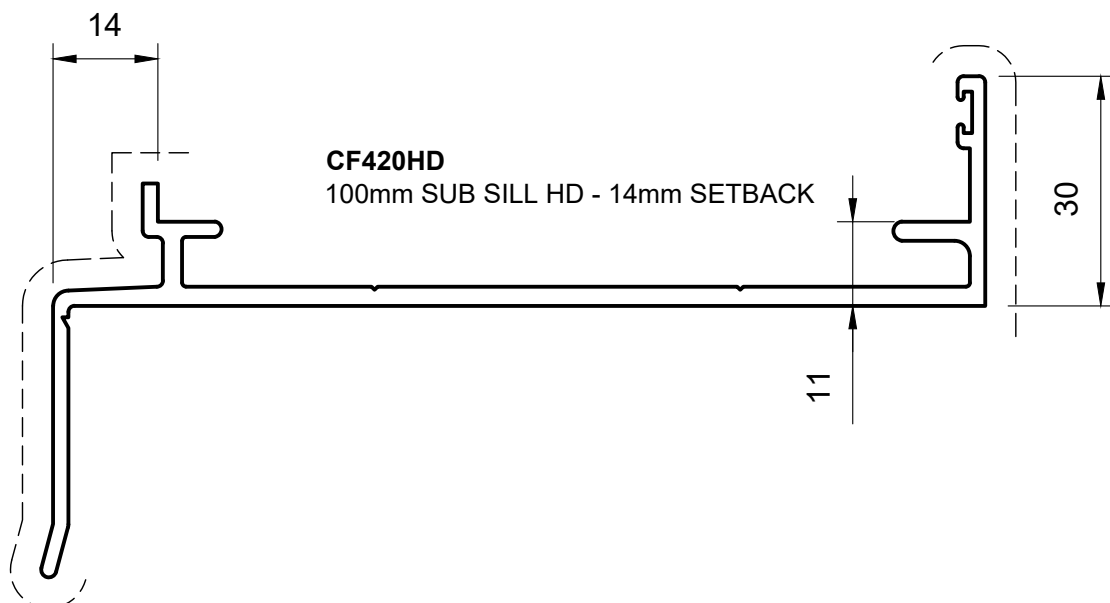
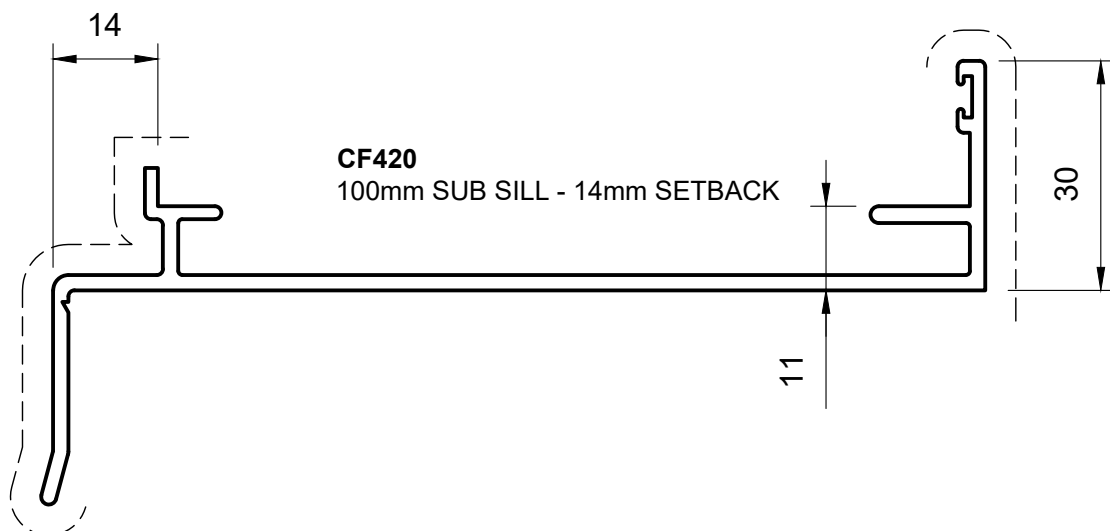
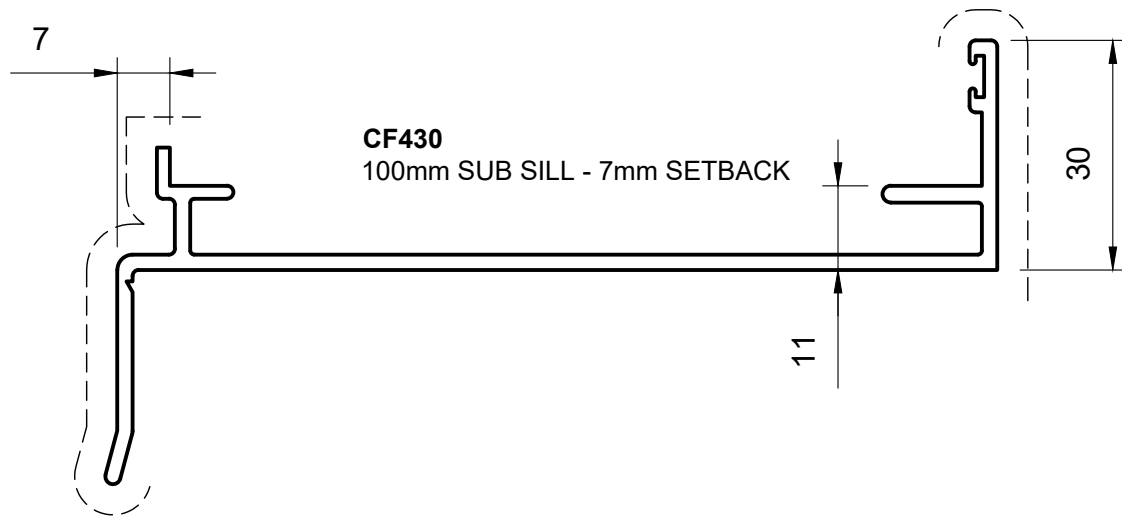

SUB HEADS & SUB SILLS

100mm SUB SILLS

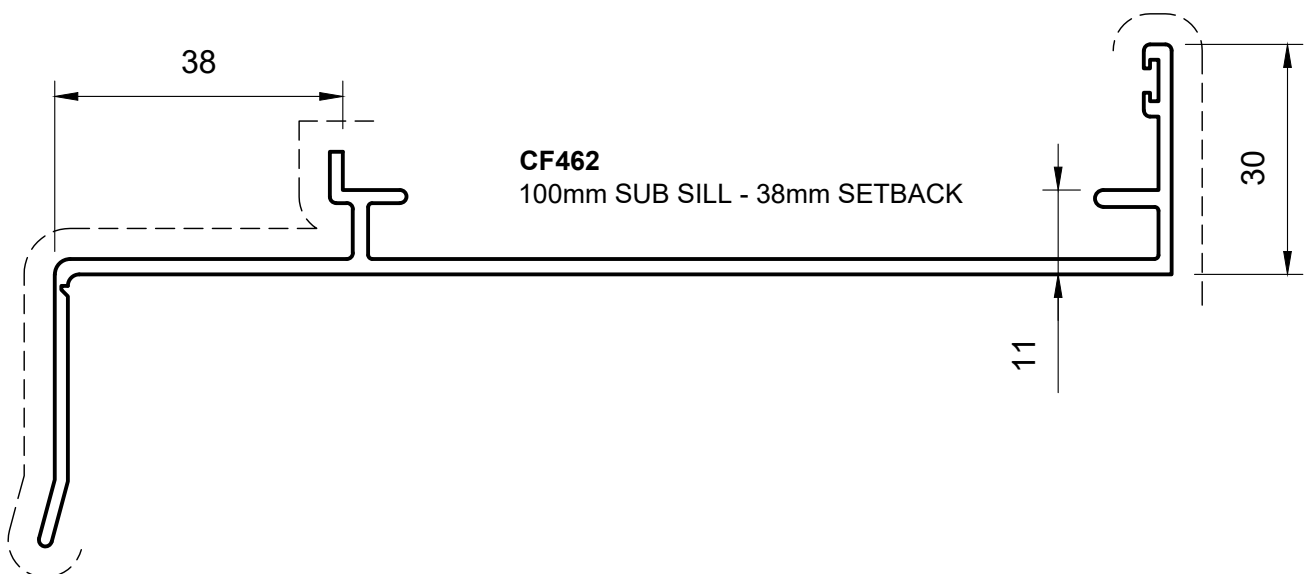
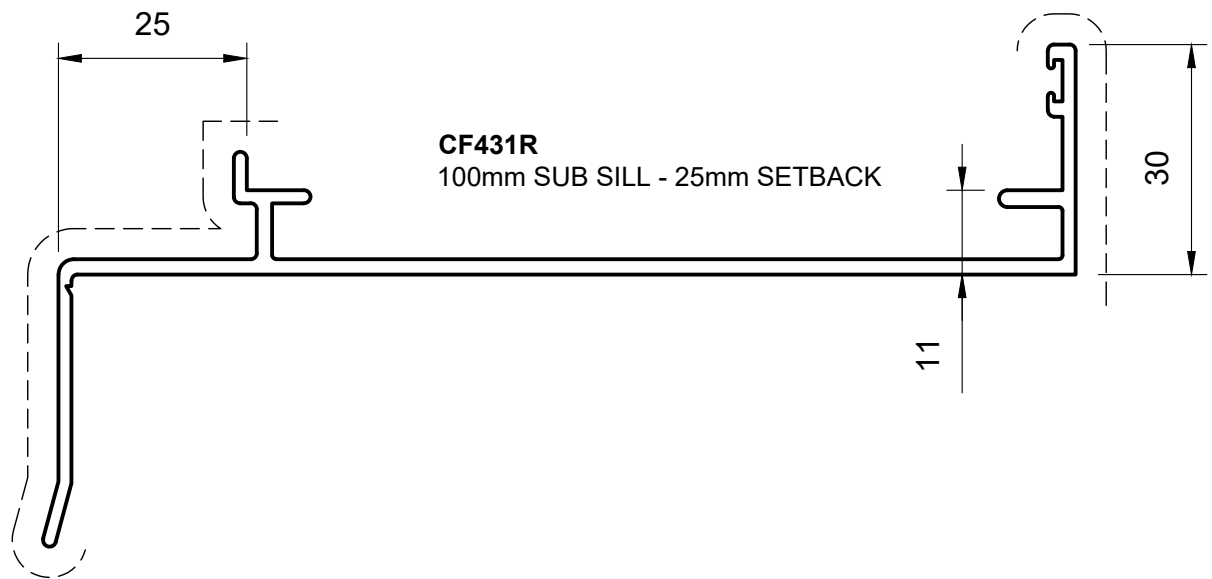

SUB HEADS & SUB SILLS

100mm SUB HEADS

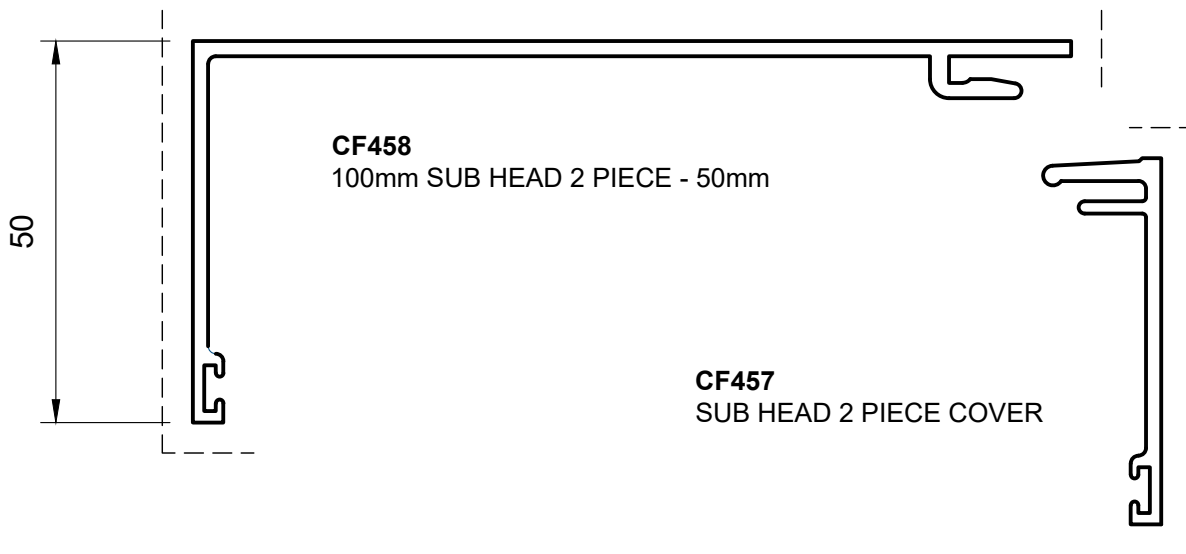
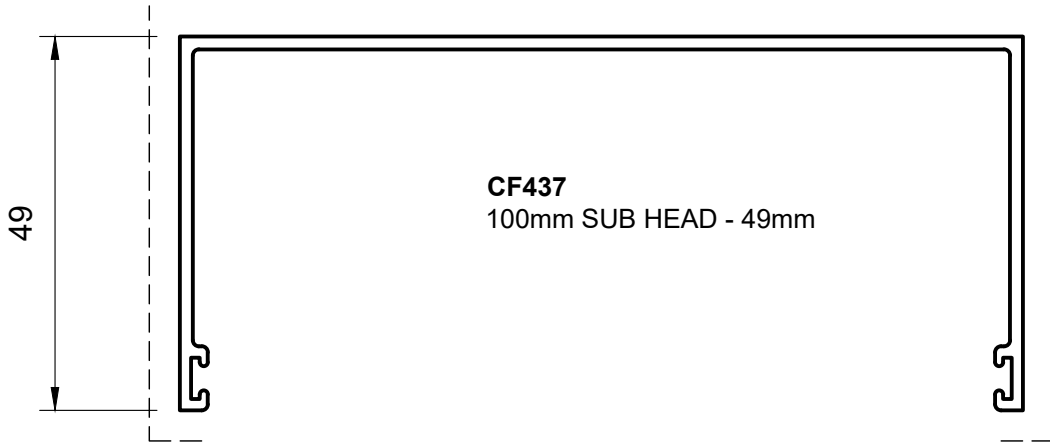

SUB HEADS & SUB SILLS

103mm SUB SILLS - FRONT CAP GLAZED ONLY

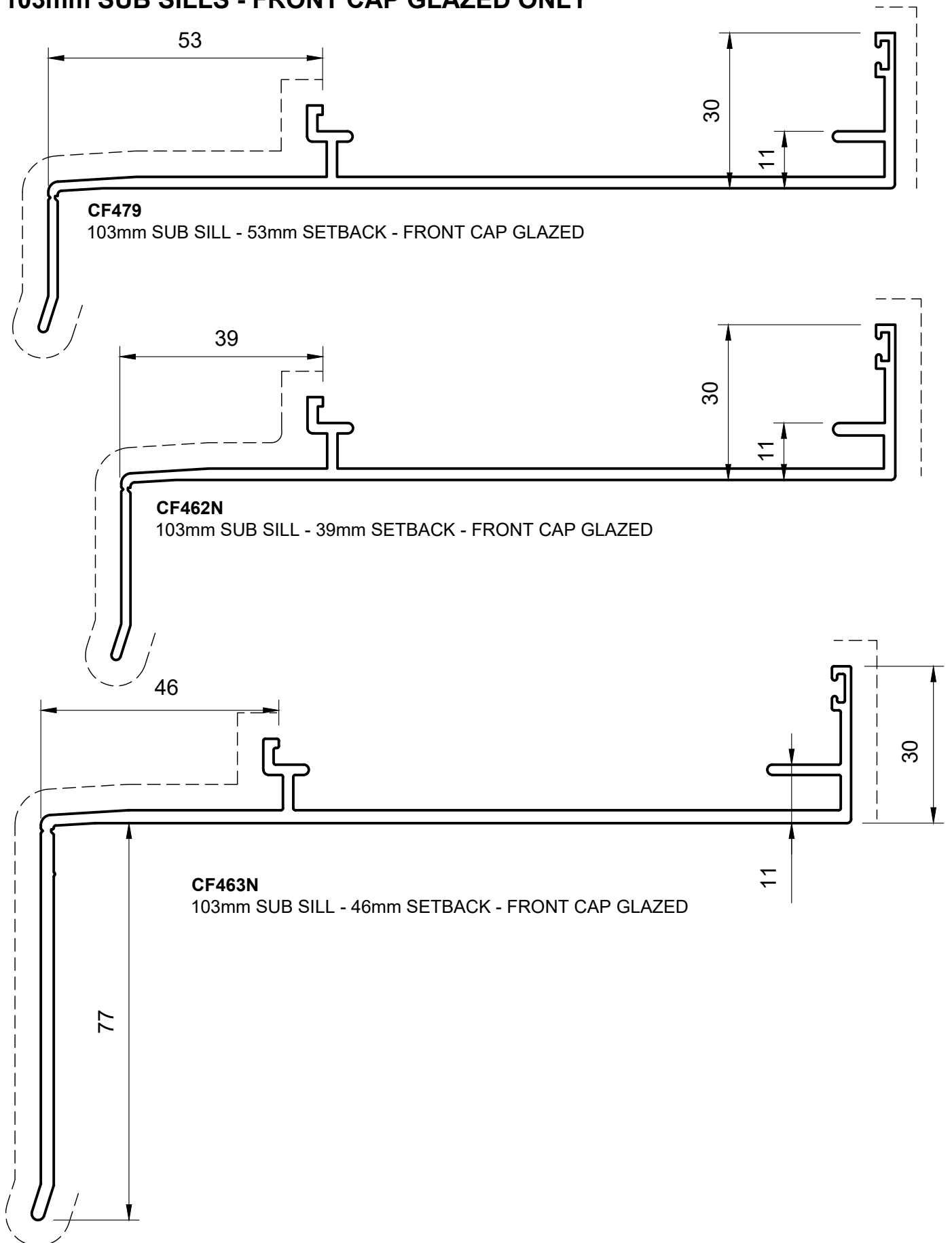

SUB HEADS & SUB SILLS

103mm SUB HEADS - FRONT CAP GLAZED ONLY

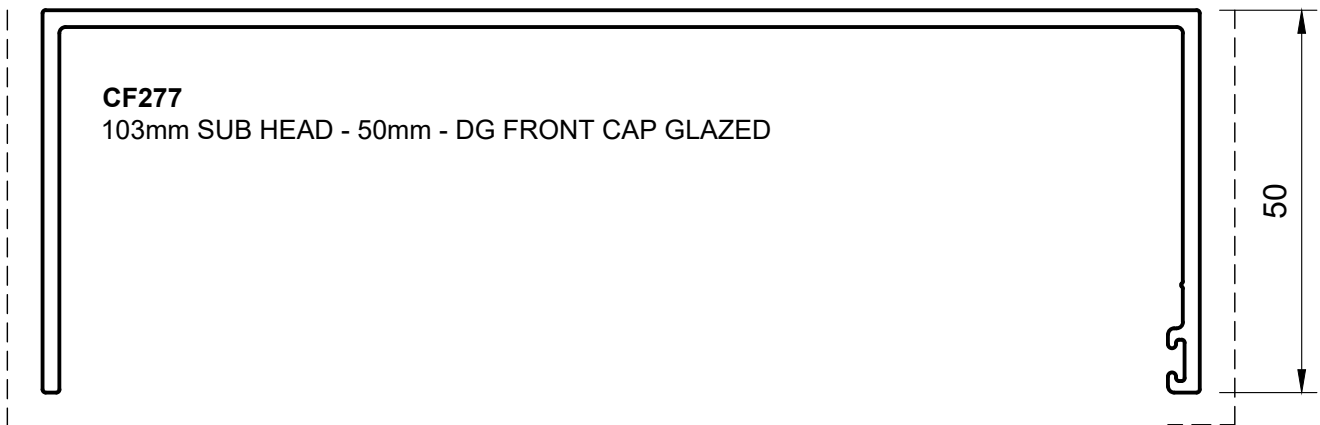
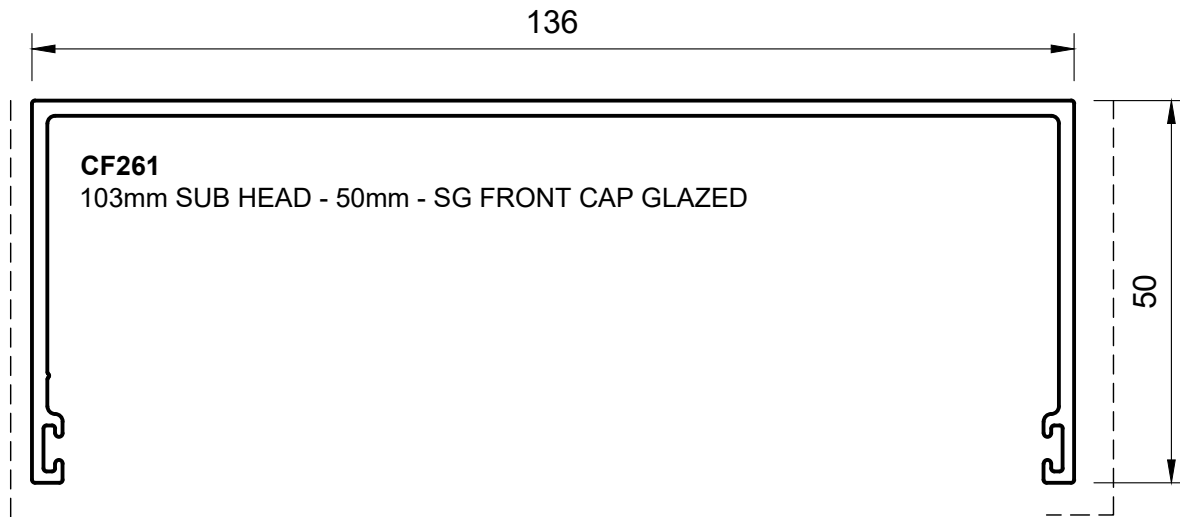

SUB HEADS & SUB SILLS

150mm SUB SILLS

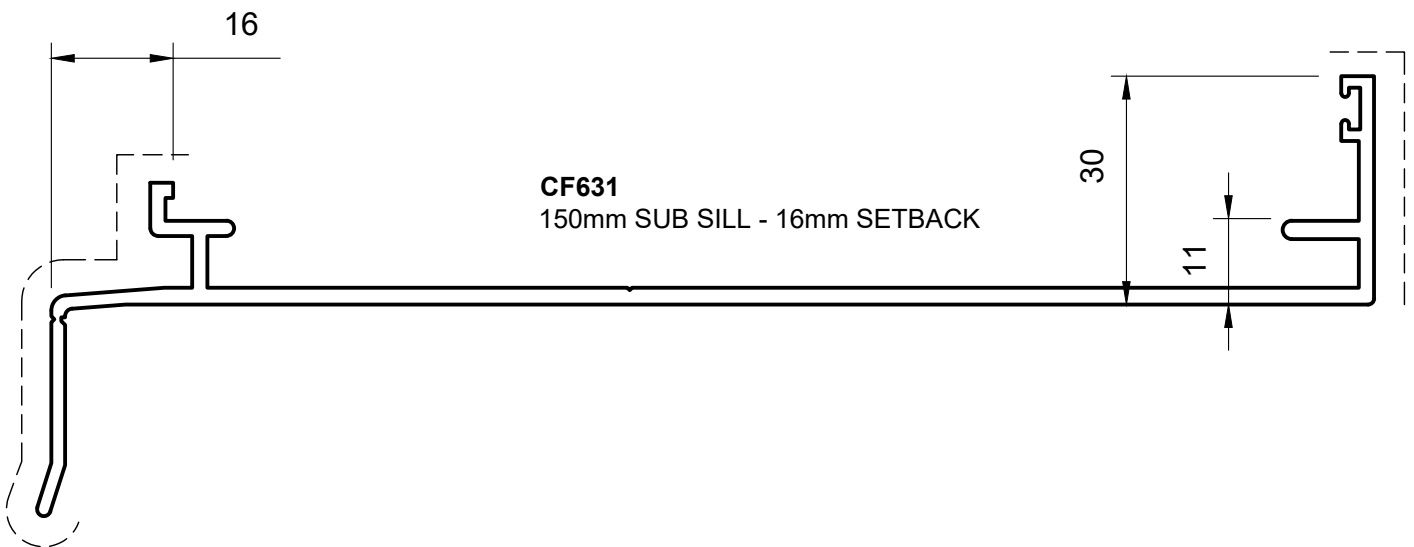
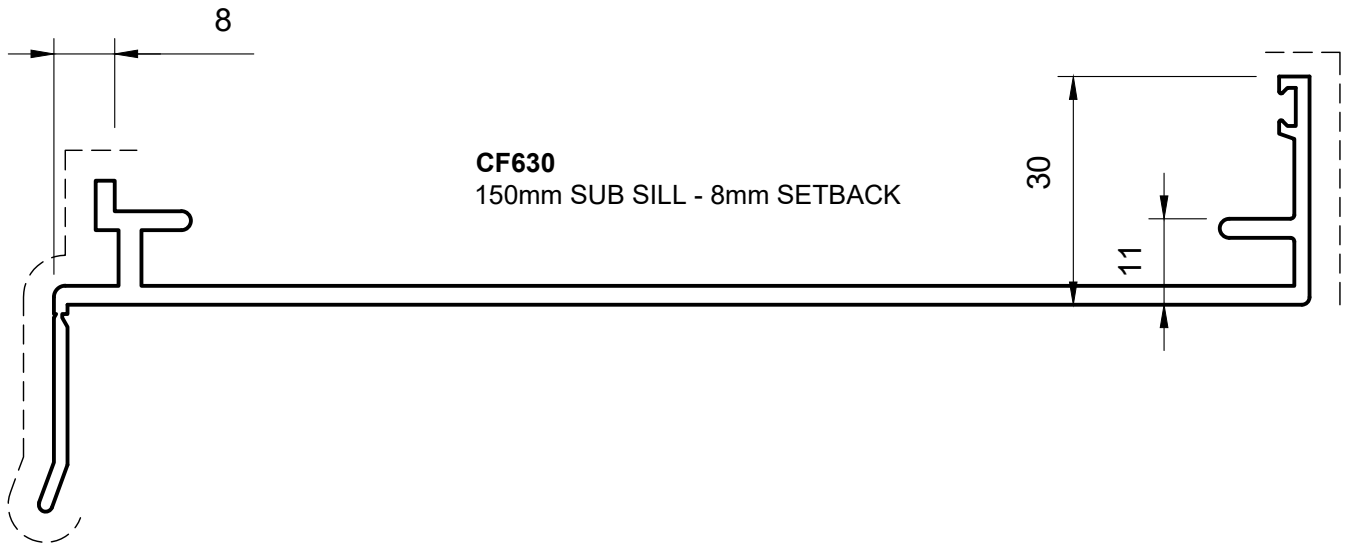

SUB HEADS & SUB SILLS

150mm SUB SILLS

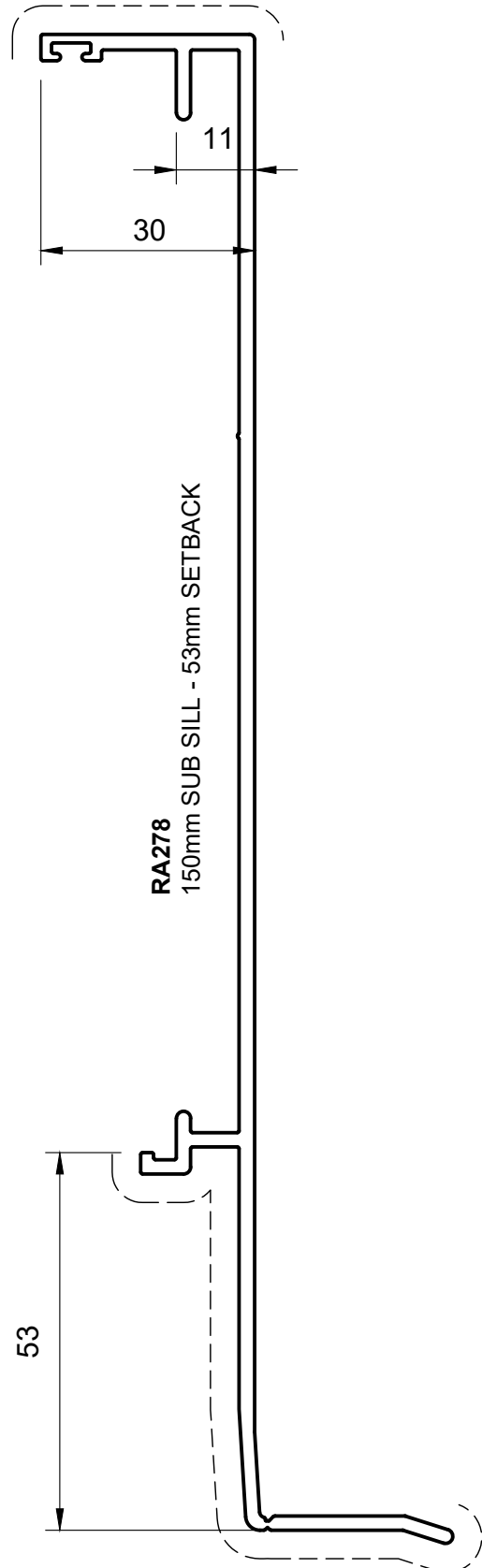
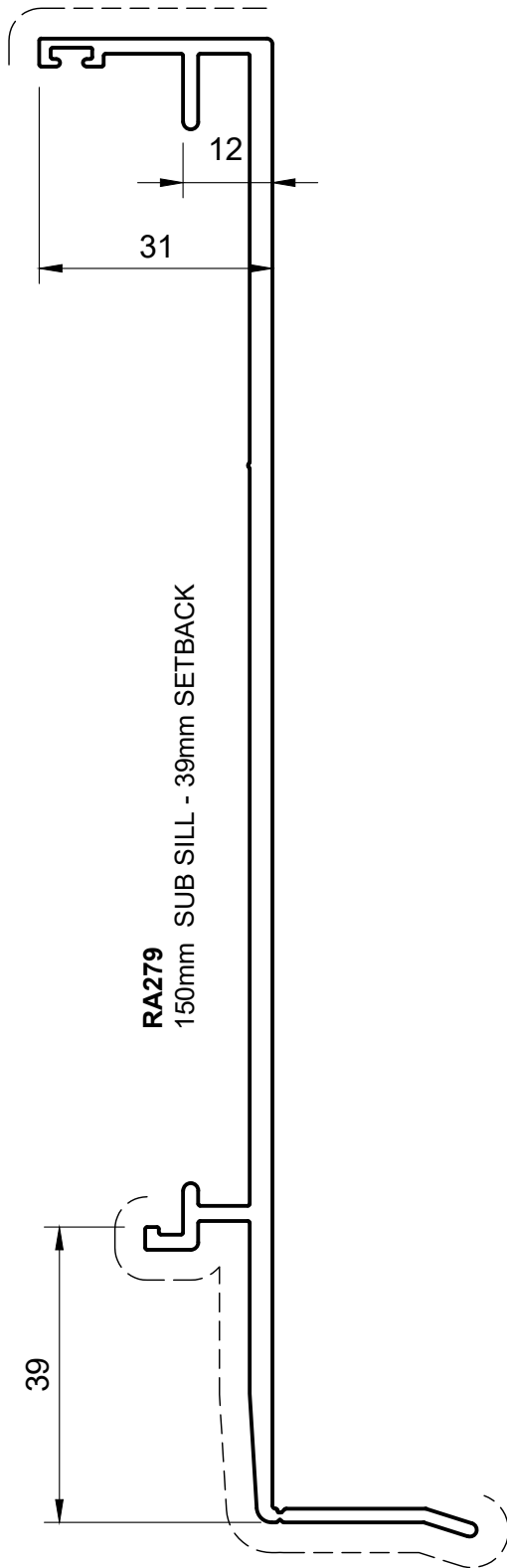

SUB HEADS & SUB SILLS

150mm SUB HEADS

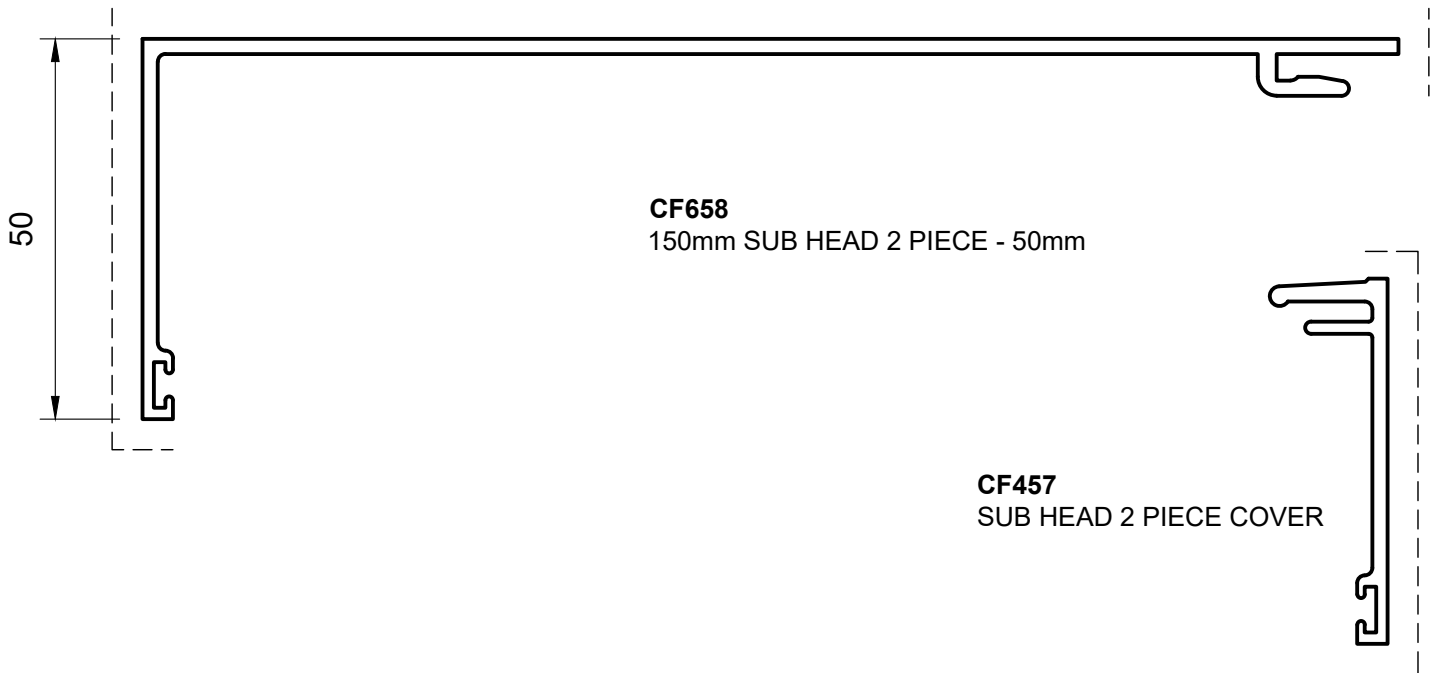
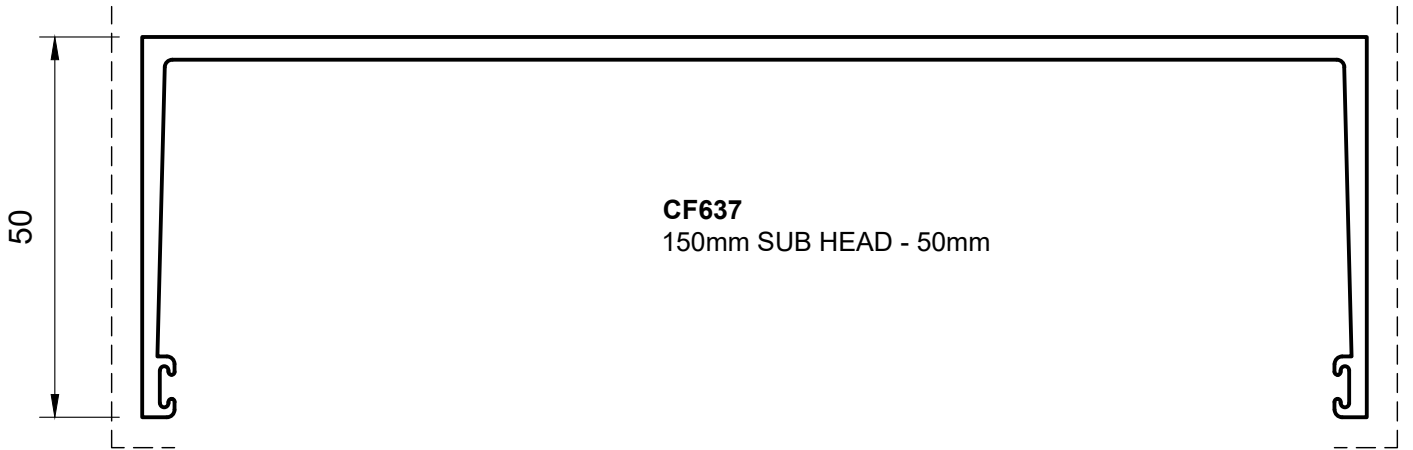

SUB HEADS & SUB SILLS

150mm SUB HEADS - FRONT CAP GLAZED ONLY

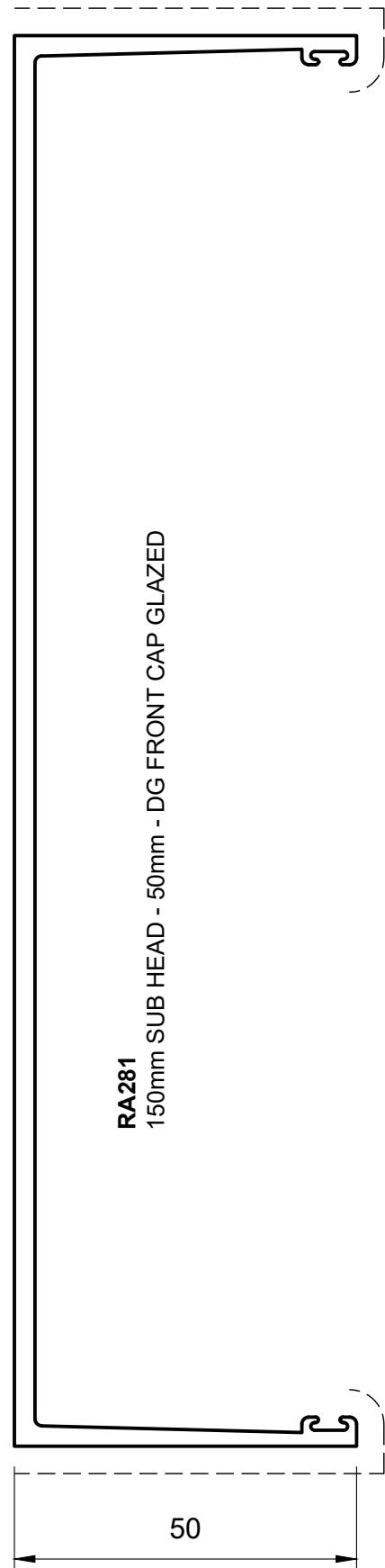
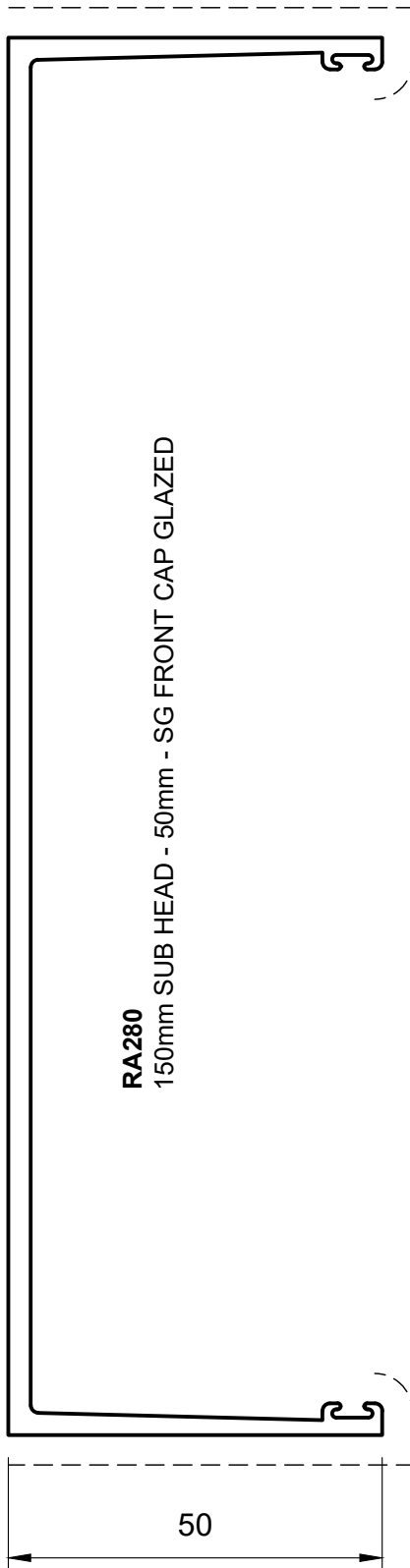

SUB HEADS & SUB SILLS

SUB SILL END DAM AND SEALING

LAY A BED OF SILICONE ACROSS THE BASE OF THE SUB SILLS, CAREFULLY SEALING INTO THE CORNERS AND UP THE VERTICAL SUB SILL LEGS

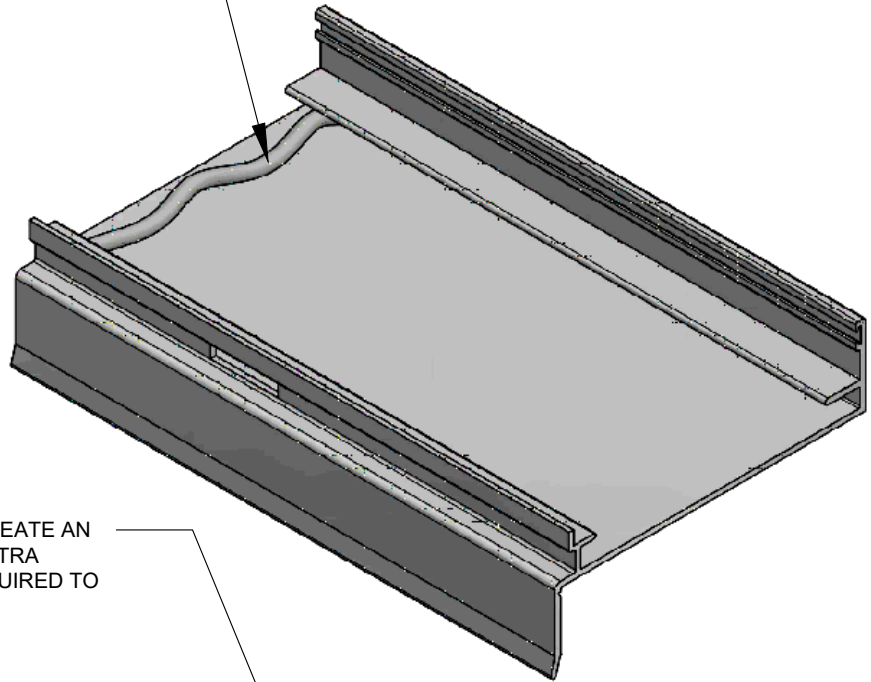

INSTALL A 25 x 25mm ANGLE TO CREATE AN END DAM IN THE SUB SILL. ADD EXTRA SILICONE IN THE CORNERS IF REQUIRED TO ENSURE WATER TIGHTNESS

RIVET ANGLE TO SUB SILL TO ENSURE THE SILICONE SEAL IS NOT DISTURBED OR BROKEN

